

BASIC THERMODYNAMICS**Module 1: Fundamental Concepts & Definitions (5)**

Thermodynamics: Terminology; definition and scope, microscopic and macroscopic approaches. Engineering Thermodynamics: Definition, some practical applications of engineering thermodynamics. System (closed system) and Control Volume (open system); Characteristics of system boundary and control surface; surroundings; fixed, moving and imaginary boundaries, examples. Thermodynamic state, state point, identification of a state through properties; definition and units, intensive and extensive various property diagrams, path and process, quasi-static process, cyclic and non-cyclic processes; Restrained and unrestrained processes; Thermodynamic equilibrium; definition, mechanical equilibrium; diathermic wall, thermal equilibrium, chemical equilibrium. Zeroth law of thermodynamics. Temperature as an important property.

Module 2: Work and Heat (5)

Mechanics definition of work and its limitations. Thermodynamic definition of work and heat, examples, sign convention. Displacement works at part of a system boundary and at whole of a system boundary, expressions for displacement works in various processes through p-v diagrams. Shaft work and Electrical work. Other types of work. Examples and practical applications.

Module 3: First Law of Thermodynamics (5)

Statement of the First law of thermodynamics for a cycle, derivation of the First law of processes, energy, internal energy as a property, components of energy, thermodynamic distinction between energy and work; concept of enthalpy, definitions of specific heats at constant volume and at constant pressure. Extension of the First law to control volume; steady state-steady flow energy equation, important applications such as flow in a nozzle, throttling, adiabatic mixing etc., analysis of unsteady processes, case studies.

Module 4: Pure Substances & Steam Tables and Ideal & Real Gases (5)

Ideal and perfect gases: Differences between perfect, ideal and real gases, equation of state, evaluation of properties of perfect and ideal gases. Real Gases: Introduction. Van der Waal's Equation of state, Van der Waal's constants in terms of critical properties, law of corresponding states, compressibility factor; compressibility chart, and other equations of state (cubic and higher orders). Pure Substances: Definition of a pure substance, phase of a substance, triple point and critical points, sub-cooled liquid, saturated liquid, vapor pressure, two-phase mixture of liquid and vapor, saturated vapor and superheated vapor states of a pure substance with water as example. Representation of pure substance properties on p-T and p-V diagrams, detailed treatment of properties of steam for industrial and scientific use (IAPWS-97, 95)

Module 5: Basics of Energy conversion cycles (3)

Devices converting heat to work and vice versa in a thermodynamic cycle Thermal reservoirs. Heat engine and a heat pump; schematic representation and efficiency and coefficient of performance. Carnot cycle.

Module 6: Second Law of Thermodynamics (5)

Identifications of directions of occurrences of natural processes, Offshoot of II law from the I. Kelvin-Planck statement of the Second law of Thermodynamic; Clasius's statement of Second law of Thermodynamic; Equivalence of the two statements; Definition of Reversibility, examples of reversible and irreversible processes; factors that make a process irreversible, reversible heat engines; Evolution of Thermodynamic temperature scale.

Module 7: Entropy (5)

Clasius inequality; statement, proof, application to a reversible cycle. $\oint (\delta Q_R/T)$ as independent of the path. Entropy; definition, a property, principle of increase of entropy, entropy as a quantitative test for irreversibility, calculation of entropy, role of T-s diagrams, representation of heat, Tds relations, Available and unavailable energy.

Module 8: Availability and Irreversibility (2)

Maximum work, maximum useful work for a system and a control volume, availability of a system and a steadily flowing stream, irreversibility. Second law efficiency.

Lecture Plan

Module	Learning Units	Hours per topic	Total Hours
1. Fundamental Concepts & Definitions	1. Thermodynamics; Terminology; definition and scope, Microscopic and Macroscopic approaches. Engineering Thermodynamics; Definition, some practical applications of engineering thermodynamics.	1	5
	2. System (closed system) and Control Volume (open system); Characteristics of system boundary and control surface; surroundings; fixed, moving and imaginary boundaries, examples.	1	
	3. Thermodynamic state, state point, identification of a state through properties; definition and units, intensive and extensive various property diagrams,	1	
	4. Path and process, quasi-static process, cyclic and non-cyclic processes; Restrained and unrestrained processes;	1	
	5. Thermodynamic equilibrium; definition, mechanical equilibrium; diathermic wall, thermal equilibrium, chemical equilibrium. Zeroth law of thermodynamics, Temperature as an important property.	1	
2. Work and Heat	6. Mechanics definition of work and its limitations. Thermodynamic definition of work and heat; examples, sign convention.	1	5
	7. Displacement work; at part of a system boundary, at whole of a system boundary,	2	
	8. Expressions for displacement work in various processes through p-v diagrams.	1	
	9. Shaft work; Electrical work. Other types of work, examples of practical applications	1	
3. First Law of Thermodynamics	10. Statement of the First law of thermodynamics for a cycle, derivation of the First law of processes,	1	5
	11. Energy, internal energy as a property, components of energy, thermodynamic distinction between energy and work; concept of enthalpy, definitions of specific heats at constant volume and at constant pressure.	1	
	12. Extension of the First law to control volume; steady state-steady flow energy equation,	1	
	13. Important applications such as flow in a nozzle, throttling, and adiabatic mixing etc. analysis of unsteady processes, case studies.	2	
4. Pure Substances &	14. Differences between perfect, ideal and real gases. Equation of state. Evaluation of properties of perfect and ideal gases	1	

Steam Tables and Ideal & Real Gases	15. Introduction. Van der Waal's Equation of state, Van der Waal's constants in terms of critical properties, law of corresponding states, compressibility factor; compressibility chart. Other equations of state (cubic and higher order)	1	5
	16. Definition of a pure substance, phase of a substance, triple point and critical points. Sub-cooled liquid, saturated liquid, vapour pressure, two phase mixture of liquid and vapour, saturated vapour and superheated vapour states of a pure substance	1	
	17. Representation of pure substance properties on p-T and p-V diagrams, Detailed treatment of properties of steam for industrial and scientific use (IAPWS-97, 95)	2	
5. Basics of Energy conversion cycles	18. Devices converting heat to work and vice versa in a thermodynamic cycle, thermal reservoirs. heat engine and a heat pump	1	3
	19. Schematic representation and efficiency and coefficient of performance. Carnot cycle.	2	
6. Second Law of Thermodynamics	20. Identifications of directions of occurrences of natural processes, Offshoot of II law from the Ist. Kelvin-Planck statement of the Second law of Thermodynamic;	2	5
	21. Clasius's statement of Second law of Thermodynamic; Equivalence of the two statements;	1	
	22. Definition of Reversibility, examples of reversible and irreversible processes; factors that make a process irreversible,	1	
	23. Reversible heat engines; Evolution of Thermodynamic temperature scale.	1	
7. Entropy	24. Clasius inequality; statement, proof, application to a reversible cycle. $\oint (\delta Q_R/T)$ as independent of the path.	1	5
	25. Entropy; definition, a property, principle of increase of entropy, entropy as a quantitative test for irreversibility,	1	
	26. Calculation of entropy, role of T-s diagrams, representation of heat quantities; Revisit to 1st law	2	
	27. Tds relations, Available and unavailable energy.	1	
8. Availability and Irreversibility	28. Maximum work, maximum useful work for a system and a control volume,	1	2
	29. Availability of a system and a steadily flowing stream, irreversibility. Second law efficiency	1	

BASIC THERMODYNAMICS

AIM: At the end of the course the students will be able to analyze and evaluate various thermodynamic cycles used for energy production - work and heat, within the natural limits of conversion.

Learning Objectives of the Course

1. Recall

- 1.1 Basic definitions and terminology
- 1.2 Special definitions from the thermodynamics point of view.
- 1.3 Why and how natural processes occur only in one direction unaided.

2. Comprehension

- 2.1 Explain concept of property and how it defines state.
- 2.2 How change of state results in a process?
- 2.3 Why processes are required to build cycles?
- 2.4 Differences between work producing and work consuming cycles.
- 2.5 What are the coordinates on which the cycles are represented and why?
- 2.6 How some of the work producing cycles work?
- 2.7 Why water and steam are special in thermodynamics?
- 2.8 Why air standard cycles are important?
- 2.9 Evaluate the performance of cycle in totality.
- 2.10 How to make energy flow in a direction opposite to the natural way and what penalties are to be paid?
- 2.11 How the concept of entropy forms the basis of explaining how well things are done?
- 2.12 How to gauge the quality of energy?

3. Application

- 3.1 Make calculations of heat requirements of thermal power plants and IC Engines.
- 3.2 Calculate the efficiencies and relate them to what occurs in an actual power plant.
- 3.3 Calculate properties of various working substances at various states.
- 3.4 Determine what changes of state will result in improving the performance.
- 3.5 Determine how much of useful energy can be produced from a given thermal source.

4. Analysis

- 4.1 Compare the performance of various cycles for energy production.
- 4.2 Explain the influence of temperature limits on performance of cycles.

- 4.3 Draw conclusions on the behavior of a various cycles operating between temperature limits.
- 4.4 How to improve the energy production from a given thermal source by increasing the number of processes and the limiting conditions thereof.
- 4.5 Assess the magnitude of cycle entropy change.
- 4.6 What practical situations cause deviations form ideality and how to combat them.
- 4.7 Why the temperature scale is still empirical?
- 4.8 Assess the other compelling mechanical engineering criteria that make thermodynamic possibilities a distant dream.

5. Synthesis

Nil

6. Evaluation

- 6.1. Assess which cycle to use for a given application and source of heat
- 6.2. Quantify the irreversibilites associated with each possibility and choose an optimal cycle.



THERMODYNAMICS



Professor K.Srinivasan
Department of Mechanical
Engineering
Indian Institute of Science
Bangalore

Sadi Carnot



Father of Thermodynamics



Fundamental Concepts and Definitions



THERMODYNAMICS:

- It is the science of the relations between heat, Work and the properties of the systems.
- How to adopt these interactions to our benefit?

Thermodynamics enables us to answer this question.



Analogy



All currencies are not equal

Eg: US\$ or A\$ or UK£ etc. Have a better purchasing power than Indian Rupee or Thai Baht or Bangladesh Taka

similarly, all forms of energy are not the same.

Human civilization has always endeavoured to obtain

- ❖ **Shaft work**
 - ❖ **Electrical energy**
 - ❖ **Potential energy**
- to make life easier



Examples



If we like to

- Rise the temperature of water in kettle
- Burn some fuel in the combustion chamber of an aero engine to propel an aircraft.
- Cool our room on a hot humid day.
- Heat up our room on a cold winter night.
- Have our beer cool.

What is the smallest amount of electricity/fuel we can get away with?



Examples (Contd)



On the other hand we burn,

- Some coal/gas in a power plant to generate electricity.
- Petrol in a car engine.

What is the largest energy we can get out of these efforts?

❖ Thermodynamics allows us to answer some of these questions



Definitions



- In our study of thermodynamics, we will choose *a small part of the universe* to which we will apply the laws of thermodynamics. We call this subset a **SYSTEM**.
- The thermodynamic system is analogous to the free body diagram to which we apply the laws of mechanics, (i.e. Newton's Laws of Motion).
- **The system is a macroscopically identifiable collection of matter on which we focus our attention** (eg: the water kettle or the aircraft engine).



Definitions (Contd...)



- The rest of the universe outside the system close enough to the system to have some perceptible effect on the system is called the **surroundings**.
- The surfaces which separates the system from the surroundings are called the **boundaries** as shown in fig below_(eg: walls of the kettle, the housing of the engine).

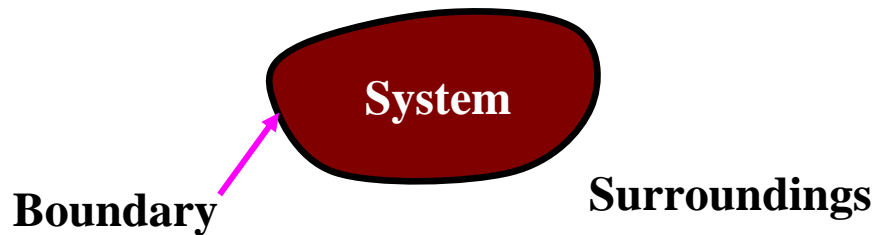



Types of System



- **Closed system** - in which no mass is permitted to cross the system boundary i.e. we would always consider a system of constant mass. We **do** permit heat and work to enter or leave but not mass.

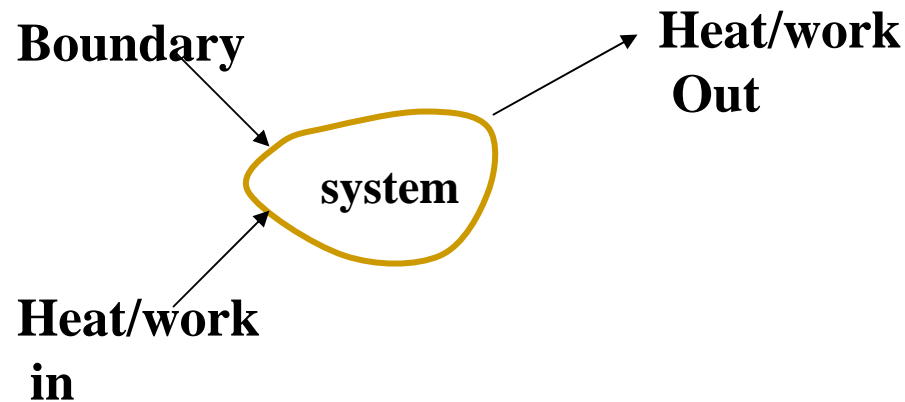

No mass entry or exit



➤ **Open system-** in which we permit mass to cross the system

boundary in either direction (from the system to surroundings or *vice versa*). In analysing open systems, we typically look at a specified region of space, and observe what happens at the boundaries of that region.

Most of the engineering devices are open system.

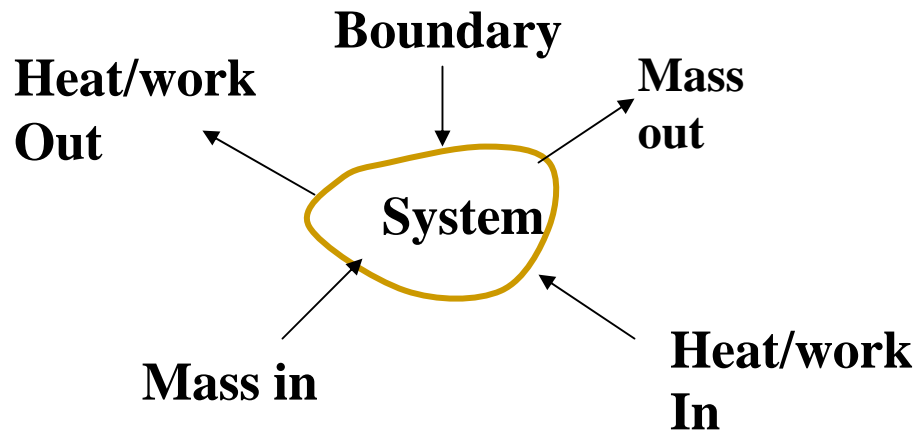



- **Isolated System** - in which there is no interaction between system and the surroundings. It is of fixed mass and energy, and hence there is no mass and energy transfer across the system boundary.

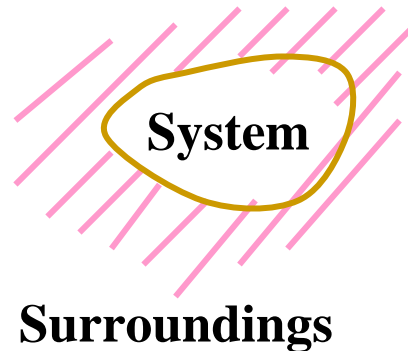



Choice of the System and Boundaries Are at Our Convenience



- We must choose the system for each and every problem we work on, so as to obtain best possible information on how it behaves.
- In some cases the choice of the system will be obvious and in some cases not so obvious.
- Important: you must be clear in defining what constitutes your system and make that choice explicit to anyone else who may be reviewing your work. (eg: *In the exam paper or to your supervisor in the work place later*)



- **The boundaries may be real physical surfaces or they may be imaginary for the convenience of analysis.**

eg: If the air in this room is the system, the floor, ceiling and walls constitute real boundaries. The plane at the open doorway constitutes an imaginary boundary.

- **The boundaries may be at rest or in motion.**

eg: If we choose a *system* that has a certain defined quantity of mass (such as gas contained in a piston cylinder device) the *boundaries* must move in such a way that they always enclose that particular quantity of mass if it changes shape or moves from one place to another

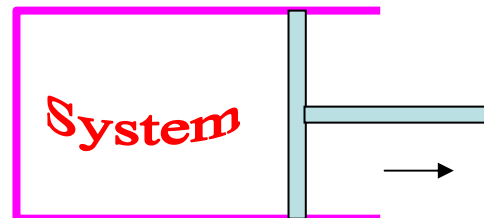



Macroscopic and Microscopic Approaches



Behavior of matter can be studied by these two approaches.

➤ In **macroscopic** approach, certain quantity of matter is considered, without a concern on the events occurring at the molecular level. These effects can be perceived by human senses or measured by instruments.

➤ eg: pressure, temperature



Microscopic Approach



➤ In **microscopic approach**, the effect of molecular motion is Considered.

eg: At microscopic level the pressure of a gas is not constant, the temperature of a gas is a function of the velocity of molecules.

Most microscopic properties cannot be measured with common instruments nor can be perceived by human senses



Property



- It is some characteristic of the system to which some physically meaningful numbers can be assigned without knowing the history behind it.
- These are macroscopic in nature.
- Invariably the properties must enable us to identify the system.
- eg: Anand weighs 72 kg and is 1.75 m tall. We are not concerned how he got to that stage. We are not interested what he ate!!.



Examples(contd)



We must choose the most appropriate set of properties.

- For example: Anand weighing 72 kg and being 1.75 m tall may be a useful way of identification for police purposes.
- If he has to work in a company you would say Anand graduated from IIT, Chennai in 1985 in mechanical engineering.
- Anand hails from Mangalore. He has a sister and his father is a poet. He is singer. ---If you are looking at him as a bridegroom!!



Examples (contd)



- All of them are properties of Anand. But you pick and choose a set of his traits which describe him best for a given situation.
- Similarly, among various properties by which a definition of a thermodynamic system is possible, a situation might warrant giving the smallest number of properties which describe the system best.



Categories of Properties



- **Extensive property:**

whose value depends on the size or extent of the system (upper case letters as the symbols).

eg: Volume, Mass (V,M).

If mass is increased, the value of extensive property also increases.

- **Intensive property:**

whose value is independent of the size or extent of the system.

eg: pressure, temperature (p, T).



Property (contd)



Specific property:

- It is the value of an extensive property per unit mass of system. (lower case letters as symbols) eg: specific volume, density (v , ρ).
- It is a special case of an intensive property.
- **Most widely referred properties in thermodynamics:**
- Pressure; Volume; Temperature; *Entropy*; *Enthalpy*; *Internal energy*

(Italicised ones to be defined later)



State:

It is the condition of a system as defined by the values of all its properties.

It gives a complete description of the system.

Any operation in which one or more properties of a system change is called a **change of state**.

Phase:

It is a quantity of mass that is homogeneous throughout in chemical composition and physical structure.

e.g. solid, liquid, vapour, gas.

Phase consisting of more than one phase is known as **heterogenous system** .



I hope you can answer the following questions related to the topics you have read till now.

Follow the link below

[problems](#)



Path And Process



The succession of states passed through during a change of state is called the **path** of the system. A system is said to go through a **process** if it goes through a series of changes in state. Consequently:

- A system may undergo changes in some or all of its properties.
- A process can be construed to be the locus of changes of state

Processes in thermodynamics are like streets in a city

eg: we have north to south; east to west; roundabouts; crescents.



Types of Processes

➤ As a matter of rule we allow one of the properties to remain a constant during a process.

➤ Construe as many processes as we can (with a different property kept constant during each of them)

➤ Complete the cycle by regaining the initial state

• Isothermal (T)

• Isobaric (p)

• Isochoric (v)

• Isentropic (s)

• Isenthalpic (h)

• Isosteric (concentration)

• Adiabatic (no heat addition or removal)



Quasi-Static Processes

The processes can be restrained or unrestrained
We need restrained processes in practice.



A quasi-static process is one in which

- The deviation from thermodynamic equilibrium is infinitesimal.
- All states of the system passes through are equilibrium states.





Quasi-Static Processes (Contd...)



- If we remove the weights slowly one by one the pressure of the gas will displace the piston gradually. It is quasistatic.
- On the other hand if we remove all the weights at once the piston will be kicked up by the gas pressure. (This is unrestrained expansion) but we don't consider that the work is done - because it is not in a sustained manner
- In both cases the systems have undergone a change of state.
- Another eg: if a person climbs down a ladder from roof to ground, it is a quasistatic process. On the other hand if he jumps then it is not a quasistatic process.



Equilibrium State



- A system is said to be in an equilibrium state if its properties will not change without some perceivable effect in the surroundings.
 - Equilibrium generally requires all properties to be uniform throughout the system.
 - There are mechanical, thermal, phase, and chemical equilibria
-



Equilibrium State (contd)



Nature has a preferred way of directing changes.

eg:

- water flows from a higher to a lower level
- Electricity flows from a higher potential to a lower one
- Heat flows from a body at higher temperature to the one at a lower temperature
- Momentum transfer occurs from a point of higher pressure to a lower one.
- Mass transfer occurs from higher concentration to a lower one



Types of Equilibrium



Between the system and surroundings, if there is no difference in

■ Pressure	→	Mechanical equilibrium
■ Potential	→	Electrical equilibrium
■ Concentration of species	→	Species equilibrium
■ Temperature	→	Thermal equilibrium

No interactions between them occur.
They are said to be in equilibrium.

Thermodynamic equilibrium implies all those together.
A system in thermodynamic equilibrium does not deliver anything.



Definition Of Temperature and Zeroth Law Of Thermodynamics



➤ **Temperature** is a property of a system which determines the degree of hotness.

➤ Obviously, it is a relative term.

eg: A hot cup of coffee is at a higher temperature than a block of ice. On the other hand, *ice is hotter than liquid hydrogen.*

Thermodynamic temperature scale is under evolution. What we have now in empirical scale.



(Contd)



➤ Two systems are said to be equal in temperature, when there is no change in their respective observable properties when they are brought together. In other words, “when two systems are at the same temperature they are in thermal equilibrium” (They will not exchange heat).

Note: They need not be in thermodynamic equilibrium.



Zeroth Law



➤ If two systems (say A and B) are in thermal equilibrium with a third system (say C) separately (that is A and C are in thermal equilibrium; B and C are in thermal equilibrium) then they are in thermal equilibrium themselves (that is A and B will be in thermal equilibrium)

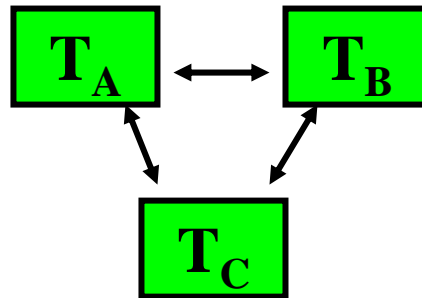



Explanation of Zeroth Law



- Let us say T_A, T_B and T_C are the temperatures of A, B and C respectively.
- A and c are in thermal equilibrium. $T_a = t_c$
- B and C are in thermal equilibrium. $T_b = t_c$

Consequence of of '0'th law

- A and B will also be in thermal equilibrium $T_A = T_B$
- Looks very logical
- All temperature measurements are based on this LAW.



Module 2



Work and Heat

We Concentrate On Two Categories Of Heat And Work



➤ Thermodynamic definition of work:

Positive work is done by a system when the **sole effect external** to the system **could be** reduced to the rise of a weight.

➤ Thermodynamic definition of heat:

It is the **energy in transition** between the system and the surroundings by virtue of the difference in temperature.



Traits of Engineers



➤ All our efforts are oriented towards how to convert heat to work or vice versa:

❖ Heat to work ➡ Thermal power plant

❖ Work to heat ➡ Refrigeration

➤ Next, we have to do it in a sustained manner (we can't use fly by night techniques!!)

• We require a combination of processes.

• Sustainability is ensured from a cycle

• A system is said to have gone through a cycle if the initial state has been regained after a series of processes.



Sign Conventions



- Work done BY the system is **POSITIVE**
- Obviously work done ON the system is **-ve**
- Heat given TO the system is **POSITIVE**
- Obviously Heat rejected by the system is **-ve**

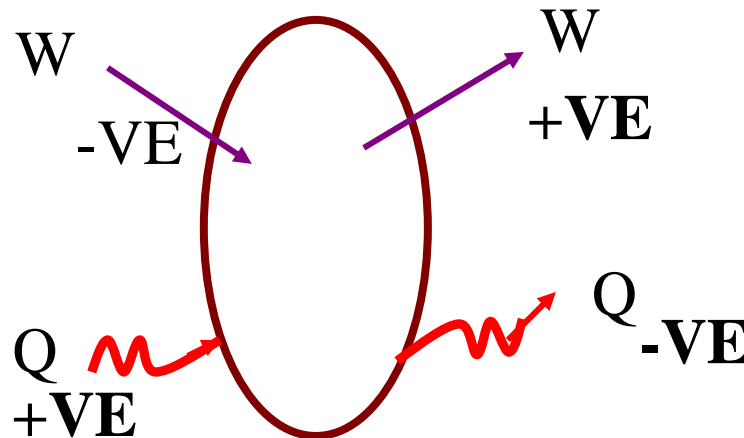

Types of Work Interaction

➤ Types of work interaction

- ❖ Expansion and compression work (displacement work)
- ❖ Work of a reversible chemical cell
- ❖ Work in stretching of a liquid surface
- ❖ Work done on elastic solids
- ❖ Work of polarization and magnetization





Notes on Heat



- All temperature changes need not be due to heat alone
eg: Friction
- All heat interaction need not result in changes in temperature
eg: condensation or evaporation



Various Types of Work



- Displacement work (pdV work)
- Force exerted, $F = p \cdot A$
- Work done

$$dW = F \cdot dL = p \cdot A \cdot dL = p \cdot dV$$

- If the piston moves through a finite distance say 1-2, Then work done has to be evaluated by integrating $\delta W = \int p dV$



(Contd)

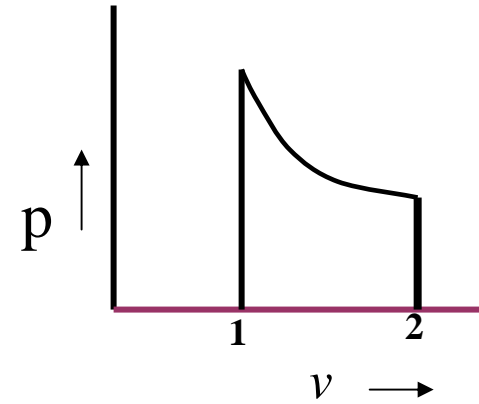
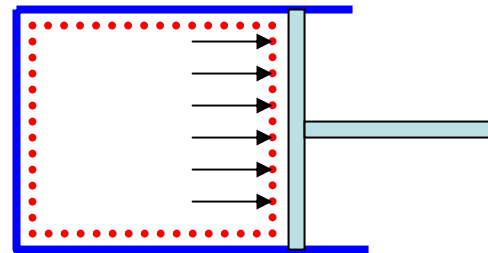
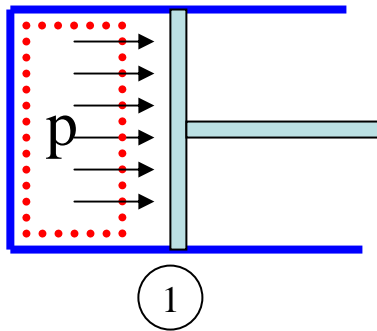
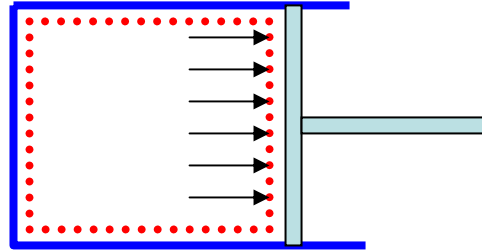
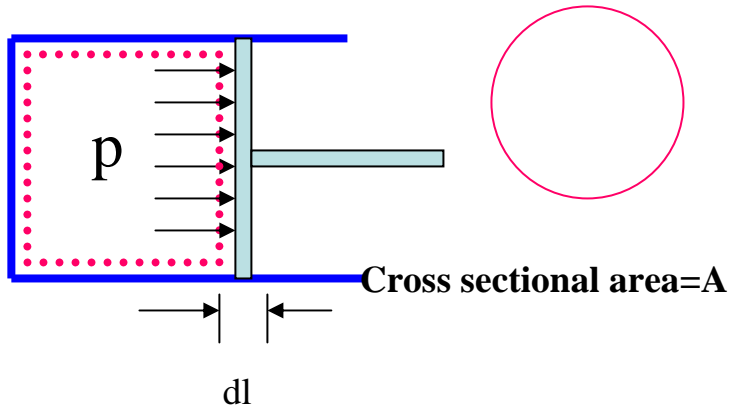



Discussion on Work Calculation



The system (shown by the dotted line) has gone through a change of state from 1 to 2. We need to know how the pressure and volume change.

Possibilities:

- Pressure might have remained constant
or
 - It might have undergone a change as per a relation $p(V)$
or
 - The volume might have remained constant
- In general the area under the process on p - V plane gives the work

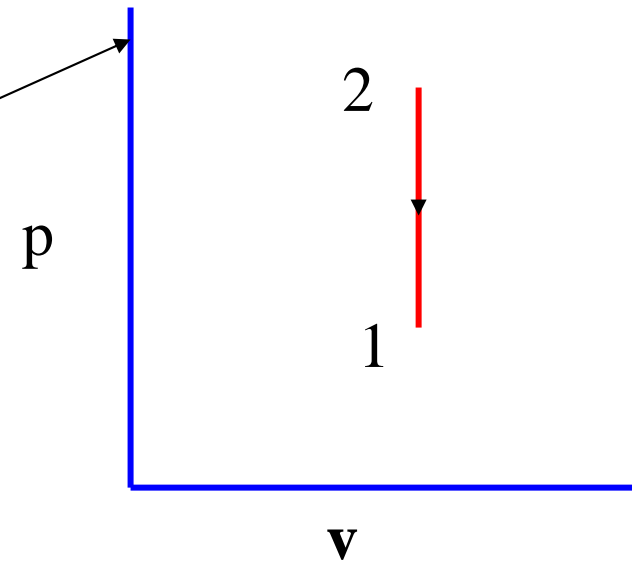
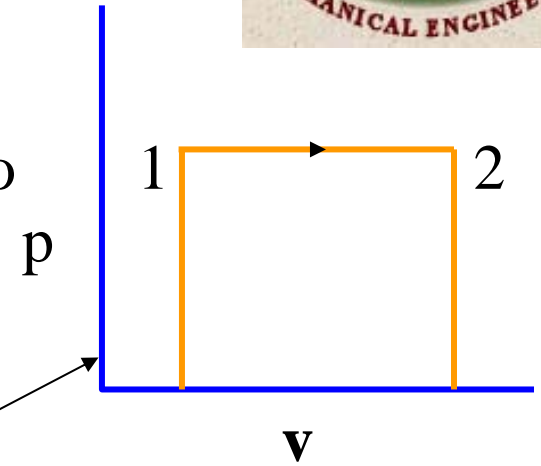



Other Possible Process



- $pV = \text{constant}$ (it will be a rectangular hyperbola)
- In general $pV^n = \text{constant}$
- ❖ **IMPORTANT:** always show the states by numbers/alphabet and indicate the direction.

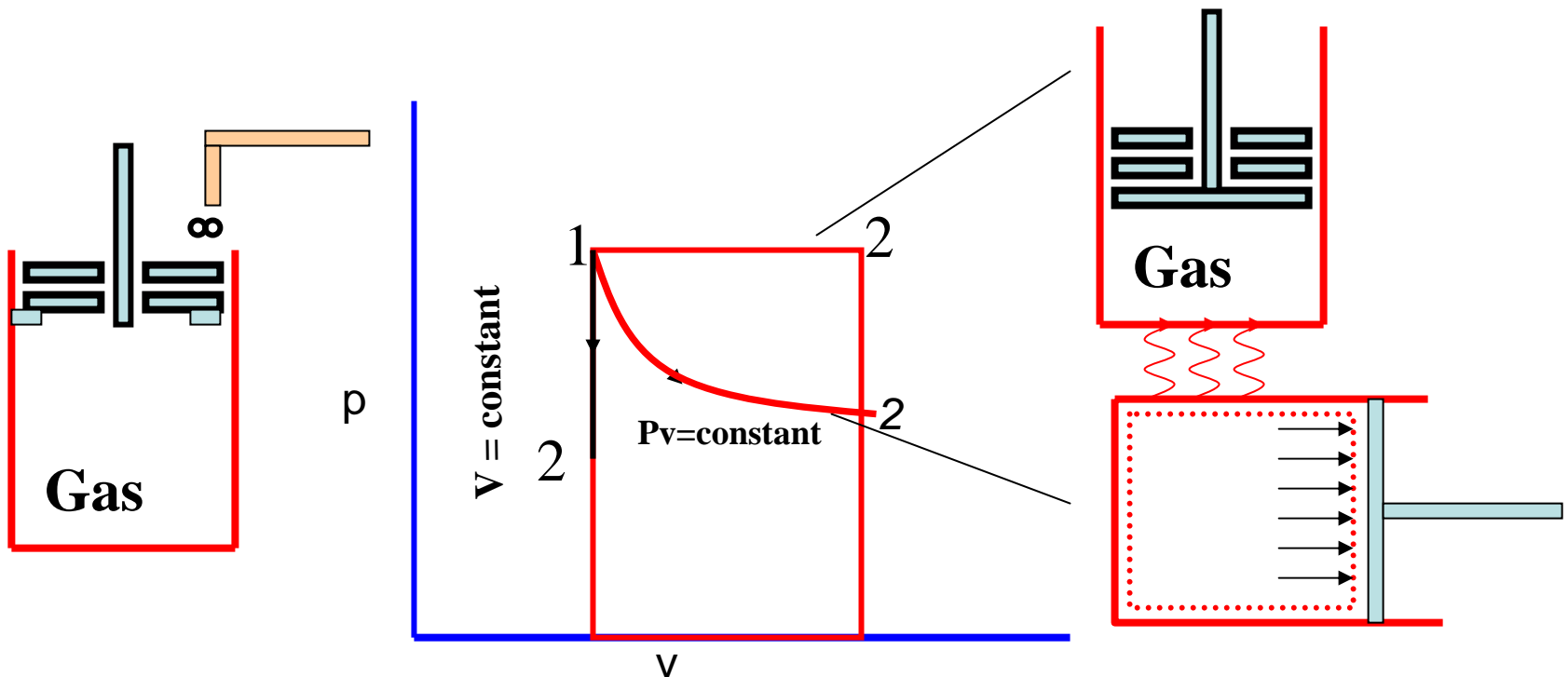

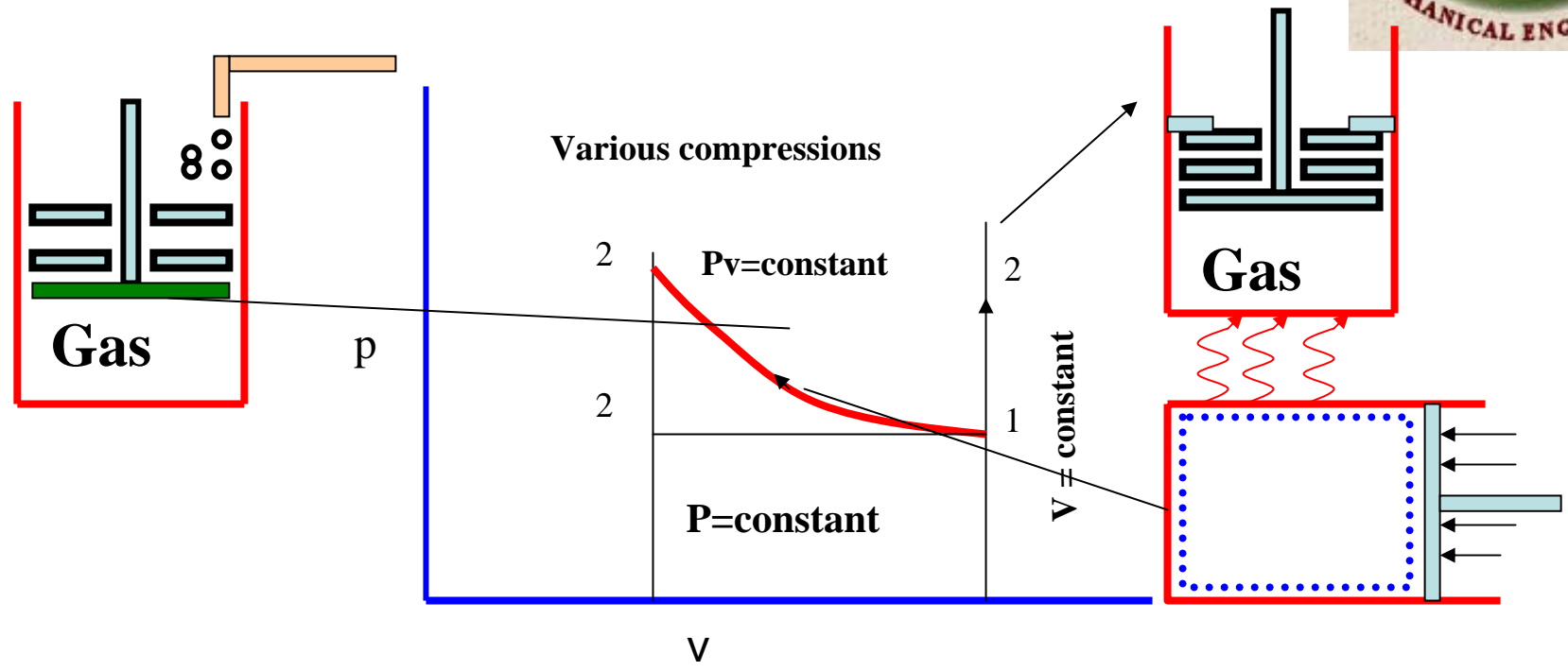

➤ $n=0$ Constant pressure

$(V_2 > V_1 - \text{expansion})$

➤ $n=1$ $p_v = \text{constant}$

$(p_2 < p_1 ; V_2 > V_1 - \text{expansion})$

➤ $n = \infty$ Constant volume

$(p_2 < p_1 - \text{cooling})$



Others Forms Of Work



❖ **Stretching of a wire:**

Let a wire be stretched by dL due to an application of a force F

Work is done on the system. Therefore $dW = -FdL$

❖ **Electrical Energy:**

Flowing in or out is always deemed to be work

$$dW = -EdC = -EIdt$$

❖ **Work due to stretching of a liquid film due to surface tension:**

Let us say a soap film is stretched through an area dA

$$dW = -\sigma dA$$

where σ is the surface tension.



Module 3



First law of thermodynamics



First Law of Thermodynamics



Statement:

- When a closed system executes a complete cycle the sum of heat interactions is equal to the sum of work interactions.

Mathematically

- $\Sigma Q = \Sigma W$

The summations being over the entire cycle

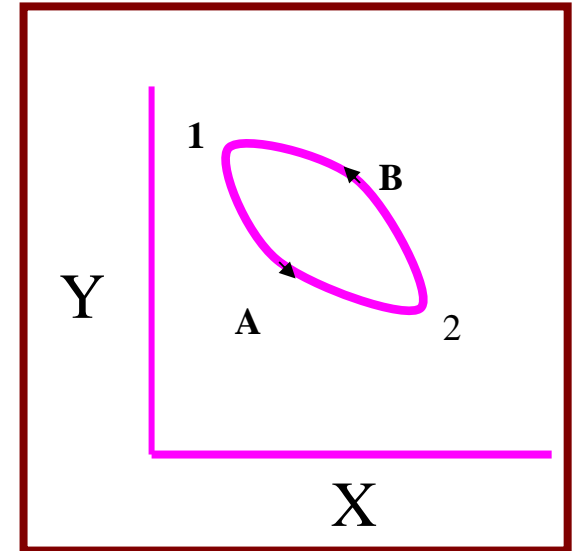



First Law(Contd...)

Alternate statement:

When a closed system undergoes a cycle the cyclic integral of heat is equal to the cyclic integral of work.

Mathematically $\oint \delta Q = \oint \delta W$

In other words for a two process cycle

$$Q_{A1-2} + Q_{B2-1} = W_{A1-2} + W_{B2-1}$$



First Law(Contd...)



$$Q_{A1-2} = \int_1^2 \delta Q$$

Along path A

$$\int_1^2 (\delta Q - \delta W) + \int_2^1 (\delta Q - \delta W) = 0$$

Along path A Along path B

Which can be written as

$$\int_1^2 (\delta Q - \delta W) - \int_1^2 (\delta Q - \delta W) = 0$$

Along path A Along path B

$$\int_1^2 (\delta Q - \delta W) = \int_1^2 (\delta Q - \delta W)$$

Along path A Along path B



First Law (contd...)



- Since A and B are arbitrarily chosen, the conclusion is, as far as a process is concerned (A or B) the difference $\delta Q - \delta W$ remains a constant as long as the initial and the final states are the same. The difference depends only on the end points of the process. Note that Q and W themselves depend on the path followed. But their difference does not.



First Law (contd...)



- This implies that the difference between the heat and work interactions during a process is a property of the system.
- This property is called the energy of the system. It is designated as E and is equal to some of all the energies at a given state.



First Law (contd...)



We enunciate the FIRST LAW for a process as

$$\delta Q - \delta W = dE$$

E consists of



$$E = U + KE + PE$$

U - internal energy

KE - the kinetic energy

PE - the potential energy

For the whole process A



$$Q - W = E_2 - E_1$$

Similarly for the process B



$$Q - W = E_1 - E_2$$



First Law(contd...)



- An isolated system which does not interact with the surroundings $Q=0$ and $W=0$. Therefore, E remains constant for such a system.
- Let us reconsider the cycle 1-2 along path A and 2-1 along path B as shown in fig.
- Work done during the path A = Area under 1-A-2-3-4
- Work done during the path B = Area under 1-B-2-3-4
- Since these two areas are not equal, the net work interaction is that shown by the shaded area.



First Law (Contd...)

- The net area is 1A2B1.
- Therefore some work is derived by the cycle.
- First law compels that this is possible only when there is also heat interaction between the system and the surroundings.
- **In other words, if you have to get work out, you must give heat in.**

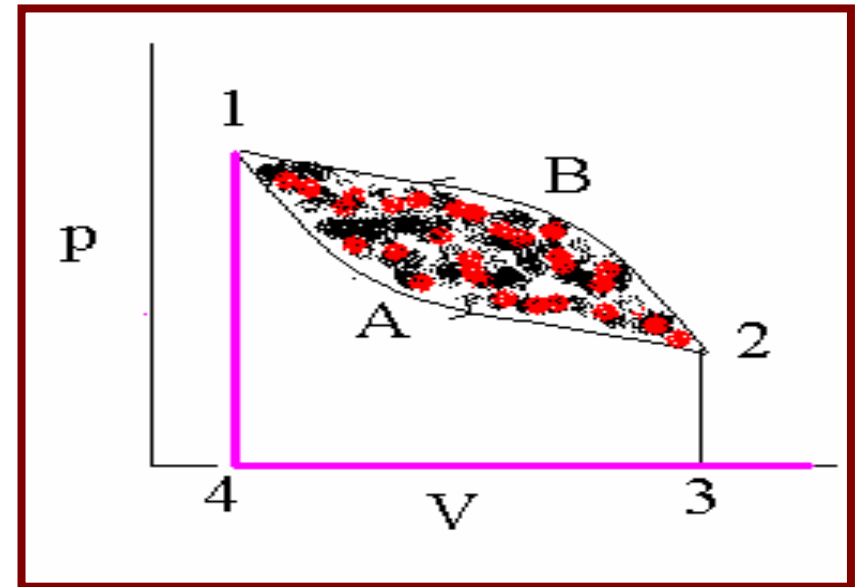



First Law (contd...)



- Thus, the first law can be construed to be a statement of conservation of energy - in a broad sense.
- In the example shown the area under curve A $<$ that under B
- The cycle shown has negative work output or it will receive work from the surroundings. Obviously, the net heat interaction is also negative. This implies that this cycle will heat the environment. (as per the sign convention).



First Law(contd...)



- For a process we can have $Q=0$ or $W=0$
- We can extract work without supplying heat(during a process) but sacrificing the energy of the system.
- We can add heat to the system without doing work(in process) which will go to increasing the energy of the system.
- Energy of a system is an extensive property



Engineering Implications



- When we need to derive some work, we must expend thermal/internal energy.
- Whenever we expend heat energy, we expect to derive work interaction (or else the heat supplied is wasted or goes to to change the energy of the system).
- If you spend money, either you must have earned it or you must take it out of your bank balance!!
- !!There is nothing called a free lunch!!



Engineering implications

(contd...)



- The first law introduces a new property of the system called the energy of the system.
- It is different from the heat energy as viewed from physics point of view.
- We have “energy in transition between the system and the surroundings” which is not a property and “energy of the system” which is a property.



Engineering Applications

(contd...)



- It appears that heat (Q) is not a property of the system but the energy (E) is.
- ❖ How do we distinguish what is a property of the system and what is not?
- The change in the value of a “property” during a process depends only on the end states and not on the path taken by a process.
- In a cycle the net in change in “every property” is zero.



Engineering implications

(contd...)



➤ If the magnitude of an entity related to the system changes during a process and if this depends only on the end states then the entity is a property of the system. (Statement 3 is corollary of statement 1)

HEAT and WORK are not properties because they depend on the path and end states.

HEAT and WORK are not properties because their net change in a cycle is not zero.



Analogy



- Balance in your bank account is a property. The deposits and withdrawals are not.
- A given balance can be obtained by a series of deposits and withdrawals or a single large credit or debit!



Analogy(contd...)



Balance is deposits *minus* withdrawals

❖ If there are no deposits and if you have enough balance, you can withdraw. But the balance will diminish

❖ If you don't withdraw but keep depositing your balance will go up.

Energy is heat *minus* work

If the system has enough energy you can extract work without adding heat. but the energy diminish

If you keep adding heat but don't extract any work, the system energy will go up.



Analogy(Contd)



- Between 2 successive 1 Januarys you had made several deposits and several withdrawals but had the same balance, then you have performed a cycle. - *it means that they have been equalled by prudent budgeting!!*
- ❖ Energy - balance; Deposits - heat interactions; Withdrawals - work interactions.
- ❖ Mathematically properties are called point functions or state functions
- ❖ Heat and work are called path functions.



Analogy (contd...)



To sum up:

I law for a cycle:

$$\oint \delta Q = \oint \delta W$$

I law for a process is

$$Q - W = \Delta E$$

For an isolated system

$$Q=0 \text{ and } W=0.$$

Therefore $\Delta E=0$

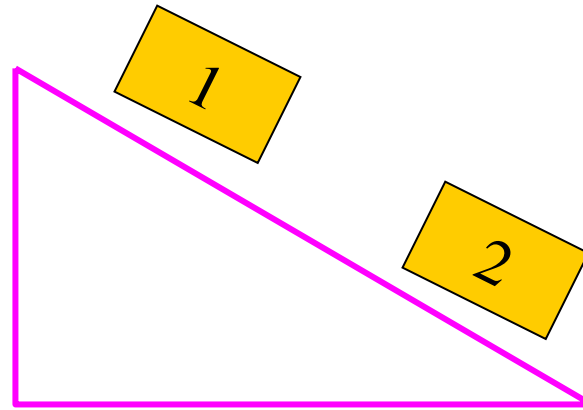

Conducting plane; Insulating rough block in vacuum

System	Q	W	ΔE
Block	0	+	-
Plane	0	-	+
Block+plane	0	0	0



Analogy (Contd..)

➤ The first law introduces the concept of energy in the thermodynamic sense.

❖ Does this property give a better description of the system than pressure, temperature, volume, density?

The answer is yes, in the broad sense.

➤ It is U that is often used rather than E . (Why? - KE and PE can change from system to system).

➤ They have the units of kJ



First law (Contd)



- Extensive properties are converted to specific extensive properties (which will be intensive properties) ., i.E., U and E with the units kJ/kg .
- A system containing a pure substance in the standard gravitational field and not in motion by itself, if electrical, magnetic fields are absent (most of these are satisfied in a majority of situations) ‘ u ’ will be ‘ e ’.



(Contd)



- The I law now becomes $Q - W = \Delta U$
- Per unit mass of the contents of the system
- If only displacement work is present
- Per unit mass basis
- Which can be rewritten as

$$\delta Q - \delta W = \delta U$$

$$(Q - W)/m = \Delta u$$

$$\delta Q - p dV = dU$$

$$\delta q - p dv = du$$

$$\delta q = du + p dv$$



Flow Process



Steady flow energy equation:

- Virtually all the practical systems involve flow of mass across the boundary separating the system and the surroundings. Whether it be a steam turbine or a gas turbine or a compressor or an automobile engine there exists flow of gases/gas mixtures into and out of the system.
- So we must know how the first Law of thermodynamics can be applied to an **open system**.



SFEE(Contd...)



- The fluid entering the system will have its own internal, kinetic and potential energies.
- Let u_1 be the specific internal energy of the fluid entering
- C_1 be the velocity of the fluid while entering
- Z_1 be the potential energy of the fluid while entering
- Similarly let u_2 , C_2 and Z_2 be respective entities while leaving.



SFEE(Contd...)

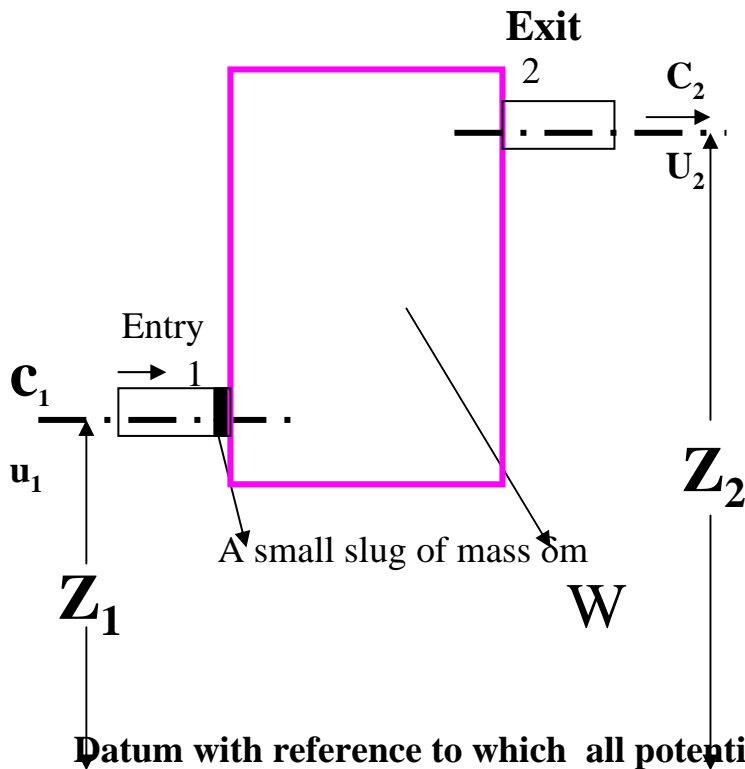

Total energy of the slug at entry

$$= \text{Int. E} + \text{Kin. E} + \text{Pot. E}$$

$$= \delta m u_1 + \delta m C_1^2 / 2 + \delta m g Z_1$$

$$= \delta m (u_1 + C_1^2 / 2 + g Z_1)$$

Focus attention on slug at entry-1



SFEE(Contd...)



- Initially the system consists of just the large rectangle. Let its energy (including IE+KE+PE) be E'
- The slug is bringing in total energy of $\delta m (u_1 + C_1^2/2 + gz_1)$
- The energy of the system when the slug has just entered will be $E' + \delta m (u_1 + c_1^2/2 + gz_1)$.



SFEE(Contd...)



➤ To push this slug in the surroundings must do some work.

If p_1 is the pressure at 1,

v_1 is the specific volume at 1,

This work must be $-p_1 dm v_1$

(-ve sign coming in because it is work done on the system)



SFEE(contd...)

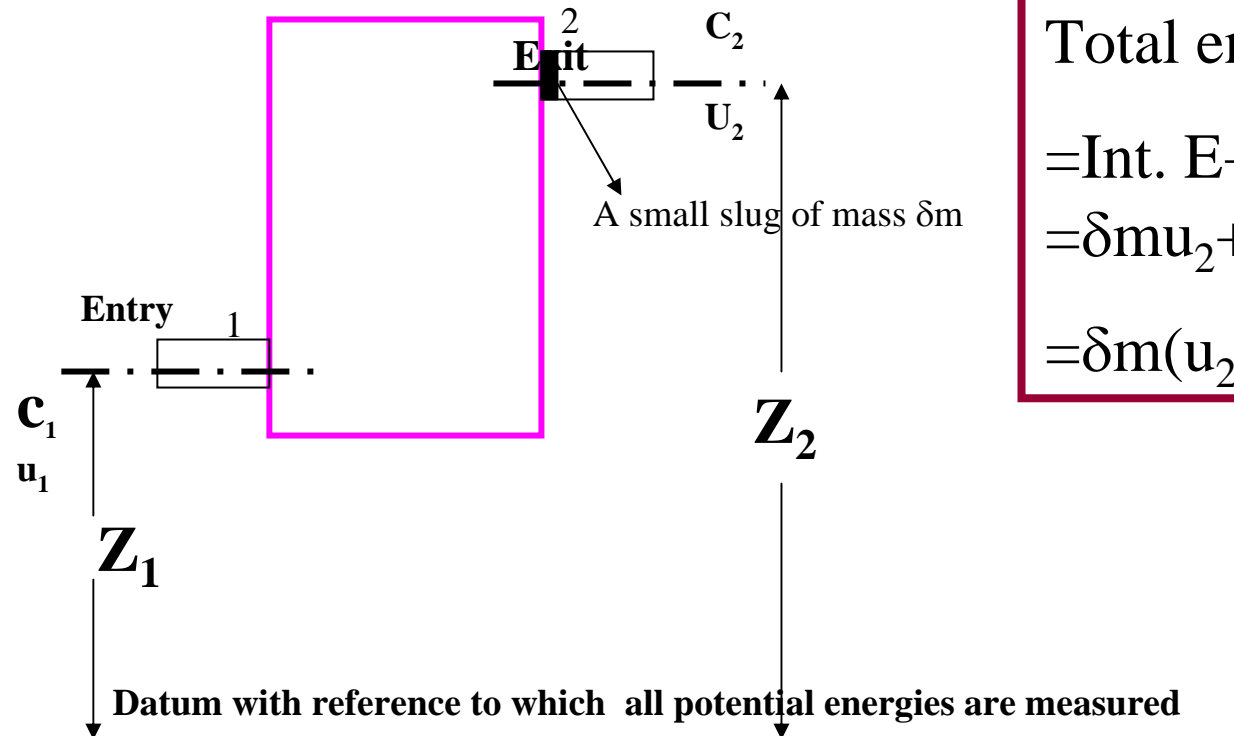

$$\begin{aligned} & \text{Total energy of the slug at exit} \\ & = \text{Int. E} + \text{Kin. E} + \text{Pot. E} \\ & = \delta m u_2 + \delta m C_2^2 / 2 + \delta m g Z_2 \\ & = \delta m (u_2 + C_2^2 / 2 + g Z_2) \end{aligned}$$

Focus Attention on Slug at Exit-2



SFEE(contd...)

- The energy of the system should have been

$$= E' + \delta m (u_2 + C_2^2/2 + gZ_2)$$

- So that even after the slug has left, the original E' will exist.
- We assume that δm is the same. This is because what goes in must come out.



SFEE(contd...)



- To push the slug out, now the system must do some work.

If p_2 is the pressure at 2,

v_2 is the specific volume at 2,

This work must be $+ p_2 \delta m v_2$

(positive sign coming in because it is work done by the system)



SFEE(contd...)



- The net work interaction for the system is
- $W + p_2 \delta m v_2 - p_1 \delta m v_1 = W + \delta m (p_2 v_2 - p_1 v_1)$
- Heat interaction Q remains unaffected.
- Now let us write the First law of thermodynamics for the steady flow process.



SFEE (contd...)

Now let us write the First law of thermodynamics for the steady flow process.

Heat interaction	= Q
Work interaction	= W + $\delta m(p_2 v_2 - p_1 v_1)$
Internal energy at 2 (E_2)	= [$E' + \delta m (u_2 + C_2^2/2 + gZ_2)$]
Internal energy at 1 (E_1)	= [$E' + \delta m (u_1 + C_1^2/2 + gZ_1)$]
Change in internal energy ($E_2 - E_1$)	= [$E' + \delta m (u_2 + C_2^2/2 + gZ_2)$] - [$E' + \delta m (u_1 + C_1^2/2 + gZ_1)$] = $\delta m[(u_2 + C_2^2/2 + gZ_2) -$ $(u_1 + C_1^2/2 + gZ_1)]$



SFEE (contd...)



- $Q - [W + dm(p_2 v_2 - p_1 v_1)] = dm [(u_2 + C_2^2/2 + gZ_2) - (u_1 + C_1^2/2 + gZ_1)]$
- $Q - W = dm[(u_2 + C_2^2/2 + gZ_2 + p_2 v_2) - (u_1 + C_1^2/2 + gZ_1 + p_1 v_1)]$
- Recognise that $h = u + pv$ from which $u_2 + p_2 v_2 = h_2$ and similarly

$$u_1 + p_1 v_1 = h_1$$

- $Q - W = dm[(h_2 + C_2^2/2 + gZ_2) - (h_1 + C_1^2/2 + gZ_1)]$

Per unit mass basis

- $q - w = [(h_2 + C_2^2/2 + gZ_2) - (h_1 + C_1^2/2 + gZ_1)]$ or
 $= [(h_2 - h_1) + (C_2^2/2 - C_1^2/2) + g(Z_2 - Z_1)]$

- SFEE



SFEE(contd...)



➤ The system can have any number of entries and exits through which flows occur and we can sum them all as follows.

➤ If 1,3,5 ... are entry points and 2,4,6... are exit points.

$$Q-W = [m_2(h_2 + C_2^2/2 + gZ_2) + m_4(h_4 + C_4^2/2 + gZ_4) + m_6(h_6 + C_6^2/2 + gZ_6) + \dots]$$

$$- [m_1(h_1 + C_1^2/2 + gZ_1) + m_3(h_3 + C_3^2/2 + gZ_3) + m_5(h_5 + C_5^2/2 + gZ_5) + \dots]$$

It is required that $m_1 + m_3 + m_5 + \dots = m_2 + m_4 + m_6 + \dots$

which is the conservation of mass (what goes in must come out)



Some Notes On SFEE



- If the kinetic energies at entry and exit are small compared to the enthalpies and there is no difference in the levels of entry and exit
- $q-w=(h_2 - h_1)=\Delta h$: per unit mass basis or $Q-W= m\Delta h$ (1)
- **For a flow process** - open system- it is the difference in the enthalpies whereas for a **non-flow processes** - closed system - it is the difference in the internal energies.



SFEE(contd...)

- $p\,v$ is called the “flow work”. This is not thermodynamic work and can't rise any weight, but necessary to establish the flow.
- For an adiabatic process $q = 0$
 - $-w = \Delta h$ (2)
- ie., any work interaction is only due to changes in enthalpy.
- Note that for a closed system it would have been $-w = \Delta u$



SFEE(Contd...)

Consider a throttling process (also referred to as wire drawing process)

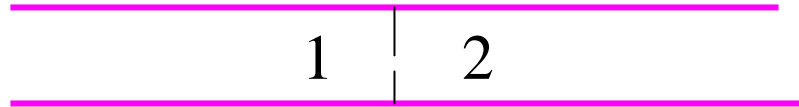

There is no work done (rising a weight) $W=0$

If there is no heat transfer $Q =0$

Conservation of mass requires that $C_1=C_2$

Since 1 and 2 are at the same level $Z_1=Z_2$

From SFEE it follows that $h_1=h_2$

Conclusion: Throttling is a constant enthalpy process
(isenthalpic process)



Heat Exchanger

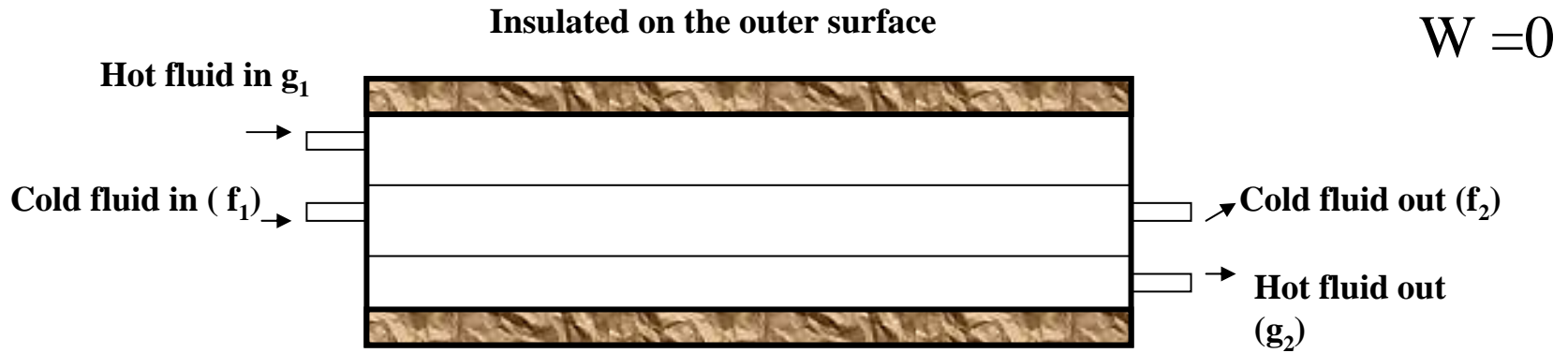

Hot fluid

$$Q_g = m_g (h_{g2} - h_{g1})$$

Cold fluid

$$Q_f = m_f (h_{f2} - h_{f1})$$

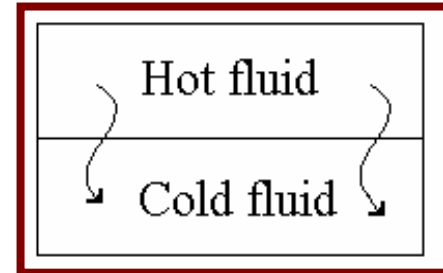



Heat Exchanger (contd...)



- ❖ **If velocities at inlet and outlet are the same**
- All the heat lost by hot fluid is received by the cold fluid.
But, for the hot fluid is -ve (leaving the system)
- Therefore $-Q_g = Q_f$
or $m_g (h_{g1} - h_{g2}) = m_f (h_{f2} - h_{f1})$
- You can derive this applying SFEE to the combined system as well (note that for the combined hot and cold system $Q=0; W=0$)
- $0 - 0 = m_f h_{f2} - m_f h_{f1} + m_g h_{g2} - m_g h_{g1}$



Adiabatic Nozzle



Normally used in turbine based power production.

It is a system where the kinetic energy is not negligible compared to enthalpy.

$$Q=0$$

$$W=0$$

SFEE becomes

$$0-0=h_2-h_1+(c_2^2/2-c_1^2/2)$$

$$\frac{c_2^2}{2} - \frac{c_1^2}{2} = h_1 - h_2$$

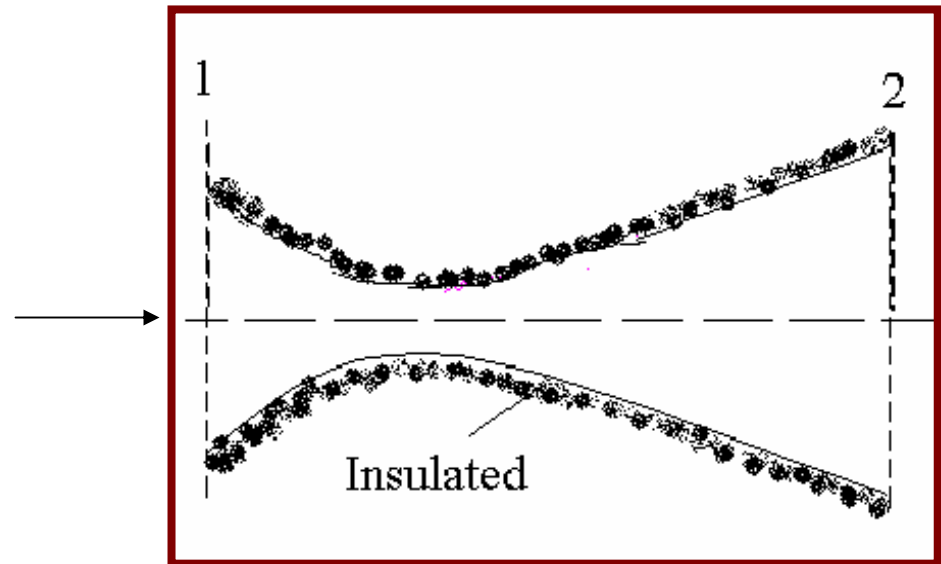



Adiabatic Nozzle

(Contd...)



➤ If h_1 is sufficiently high we can convert it into kinetic energy by passing it through a nozzle. This is what is done to steam at high pressure and temperature emerging out of a boiler or the products of combustion in a combustion chamber (which will be at a high temperature and pressure) of a gas turbine plant. Usually, C_1 will be small - but no assumptions can be made.



Analysis of Air Conditioning Process



1. Heating of Moist Air

Application of SFEE

(system excluding the heating element)

$$q - 0 = m_a(h_2 - h_1)$$

Air will leave at a higher enthalpy than at inlet.

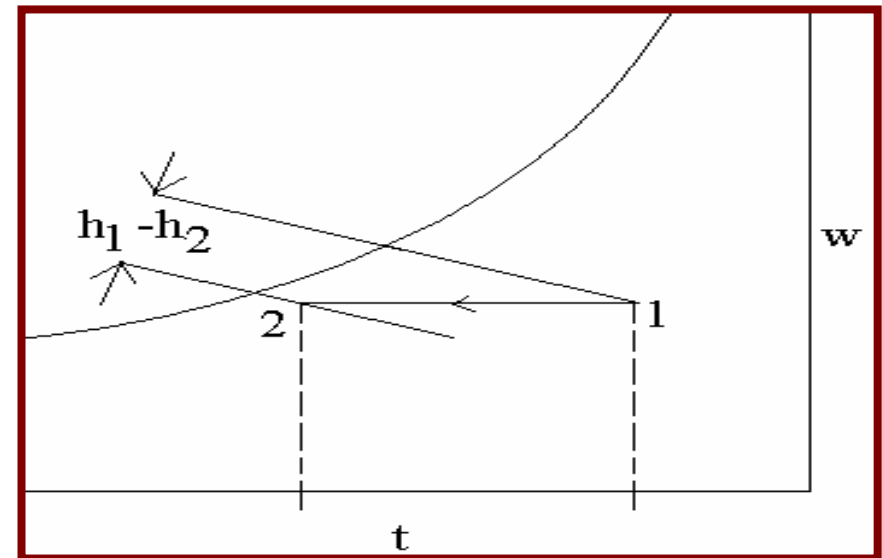



Air Conditioning Process(Contd...)



2. Cooling of moist air:

Two possibilities:

a) Sensible cooling (the final state is not below the dew point)

$$-q = m_a(h_2 - h_1) \quad \text{or} \quad q = m_a(h_1 - h_2)$$

Air will leave at a lower enthalpy than at inlet.

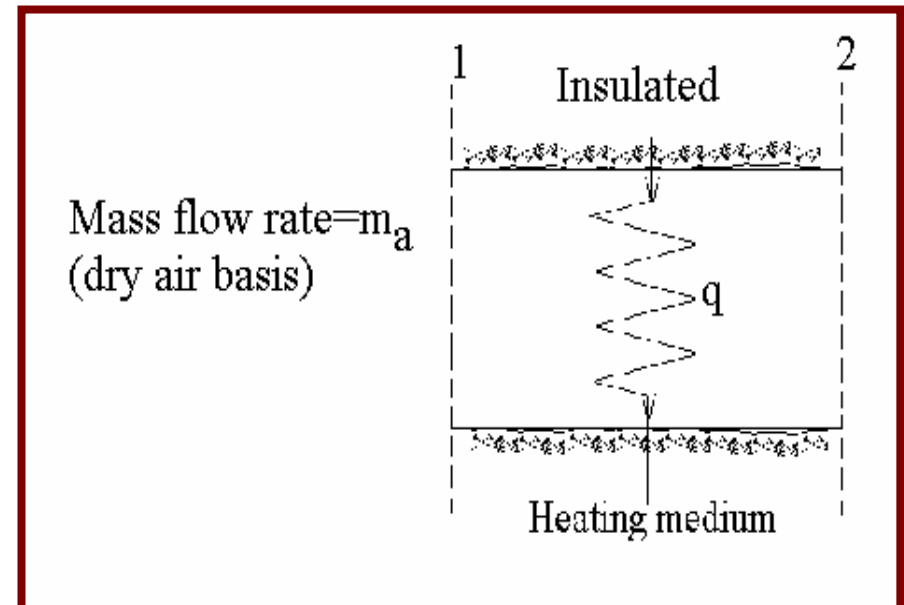
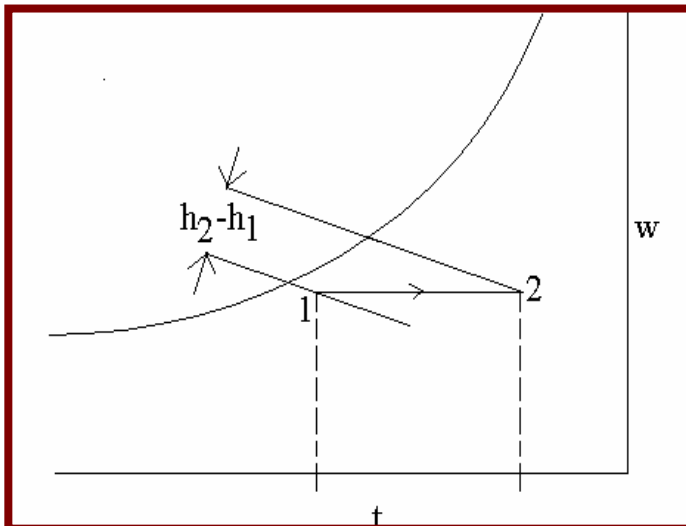



Moist Air(contd...)



b. Moisture separates out

- SFEE yields

$$-q - 0 = m_a(h_2 - h_1) + m_w h_w$$

- Moisture conservation

Humidity ratio of entering air at 1 = W_1

Moisture content = $m_a W_1$

Humidity ratio of leaving air at 2 = W_2

Moisture content = $m_a W_2$

Moisture removed = m_w

- What enters must go out !



Moisture Air (Contd...)



$$m_a W_1 = m_a W_2 + m_w$$

$$m_w = m_a (W_1 - W_2)$$

Substituting into SFEE

$$q = m_a [(h_1 - h_2) - (W_1 - W_2) h_w]$$

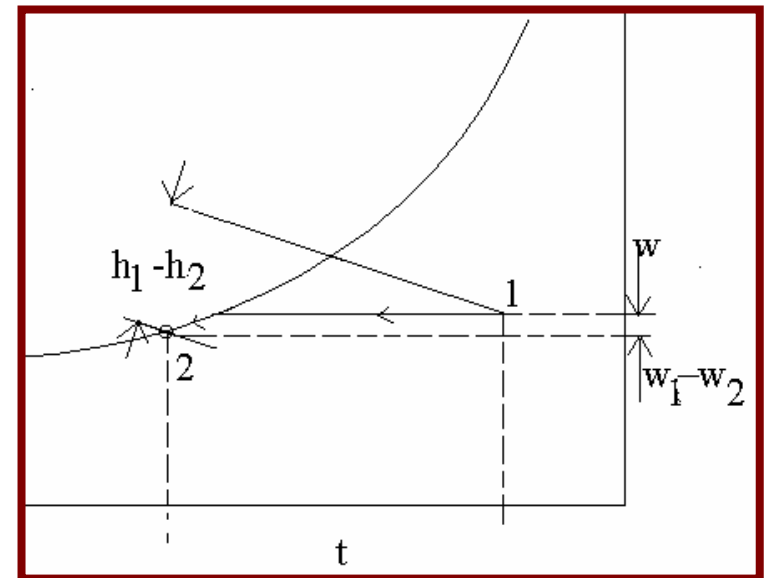
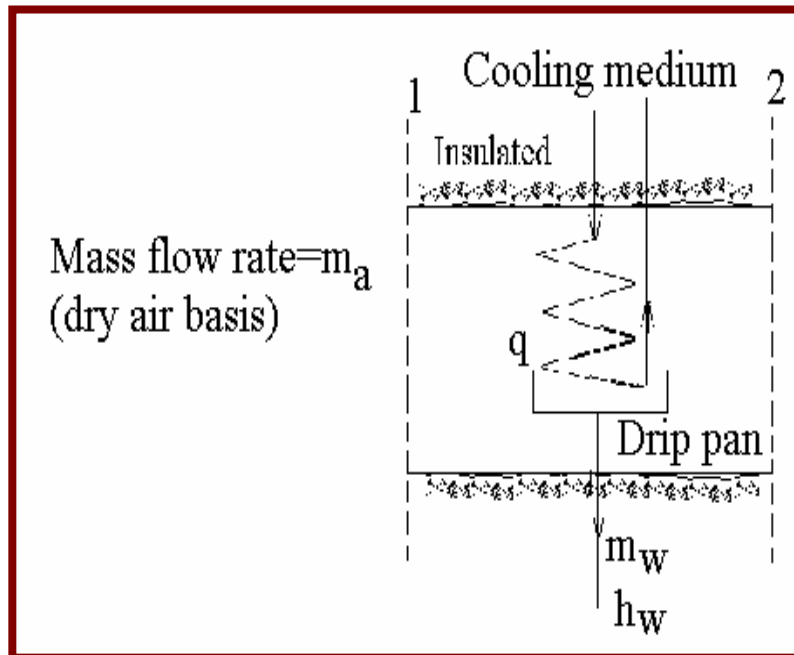



3. Adiabatic Mixture of Two Streams of Air at Separate States



SFEE

- $0-0=m_{a3}h_3-m_{a1}h_1-m_{a2}h_2$
- Dry air conservation
- $m_{a3} = m_{a1} + m_{a2}$
- Moisture conservation
- $m_{a3} w_3 = m_{a1} w_1 + m_{a2} w_2$
- Eliminate m_{a3}
- $(m_{a1}+m_{a2})h_3=m_{a1}h_1+ m_{a2}h_2$
- $m_{a1} (h_3- h_1) =m_{a2} (h_2- h_3)$

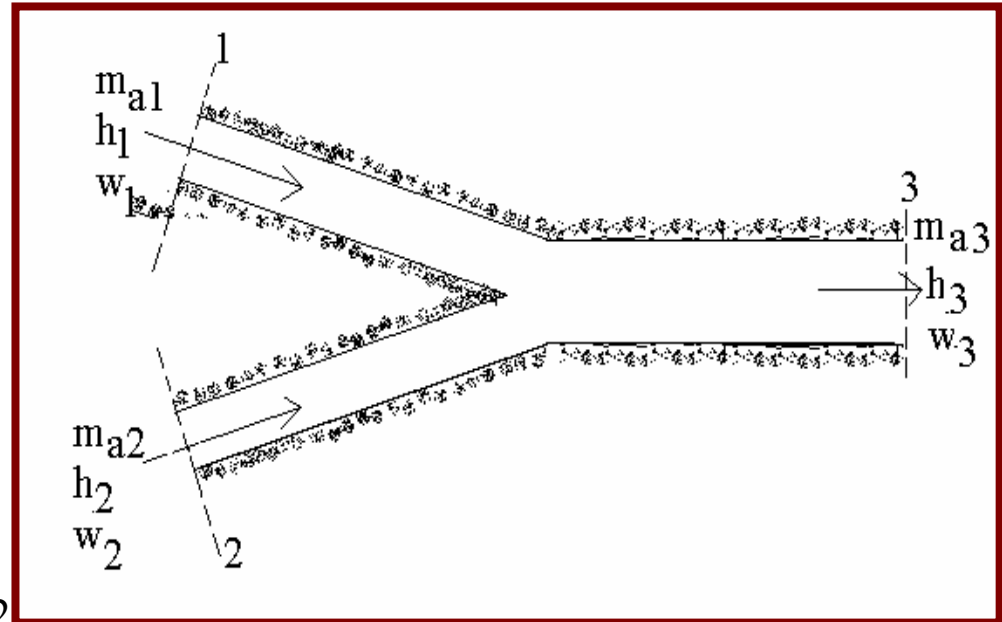



Adiabatic mixture

(contd...)



$$\frac{(w_3 - w_1)}{(w_2 - w_3)} = \frac{m_{a2}}{m_{a1}}$$

$$\frac{(t_3 - t_1)}{(t_2 - t_3)} = \frac{m_{a2}}{m_{a1}}$$

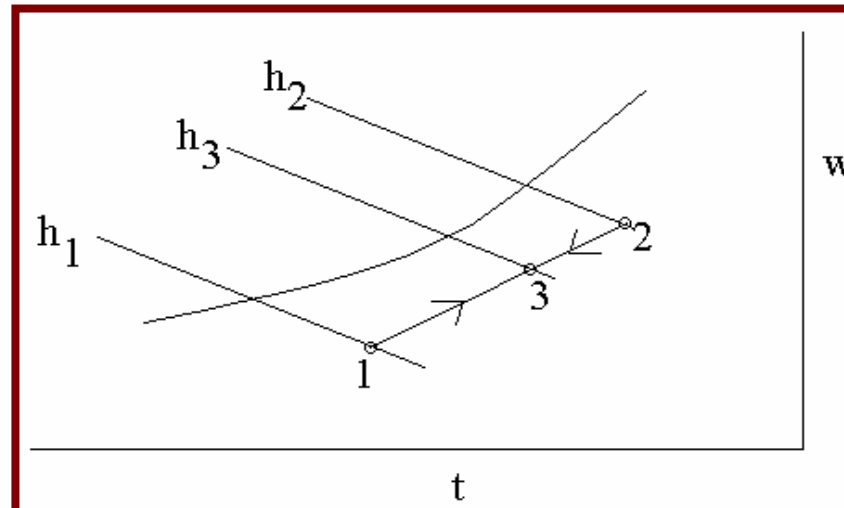



Adiabatic mixture (contd...)



Moral: 1. The outlet state lies along the straight line joining the states of entry streams

Moral: 2. The mixture state point divides the line into two segments in the ratio of dry air flow rates of the incoming streams



4. Spraying of Water Into a Stream of Air



SFEE

$$\blacktriangleright 0-0 = m_a h_2 - m_a h_1 - m_w h_w$$

❖ Moisture conservation

$$\blacktriangleright m_a w_2 = m_a w_1 + m_w$$

$$\blacktriangleright \text{or } m_w = m_a (w_2 - w_1)$$

➤ Substitute in SFEE

$$\blacktriangleright m_a (h_2 - h_1) = m_a (w_2 - w_1) h_w$$

$$\blacktriangleright \text{or } h_w = (h_2 - h_1) / (w_2 - w_1)$$

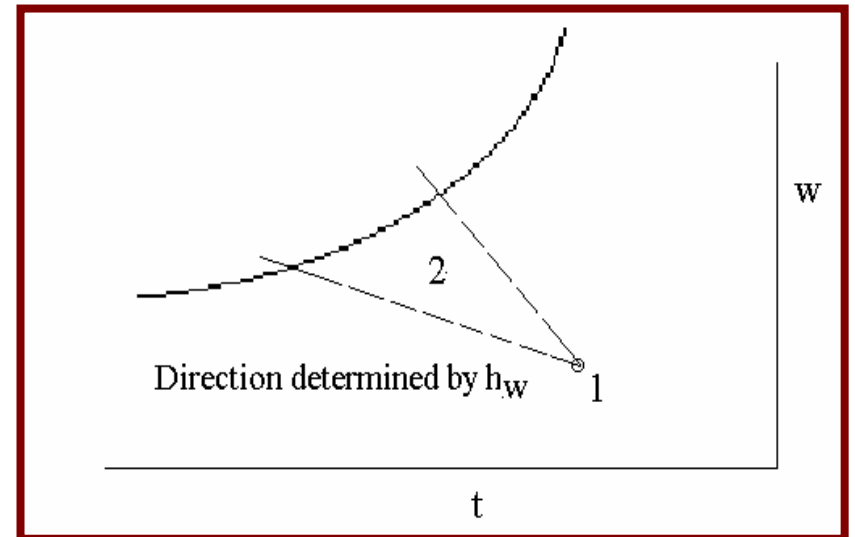
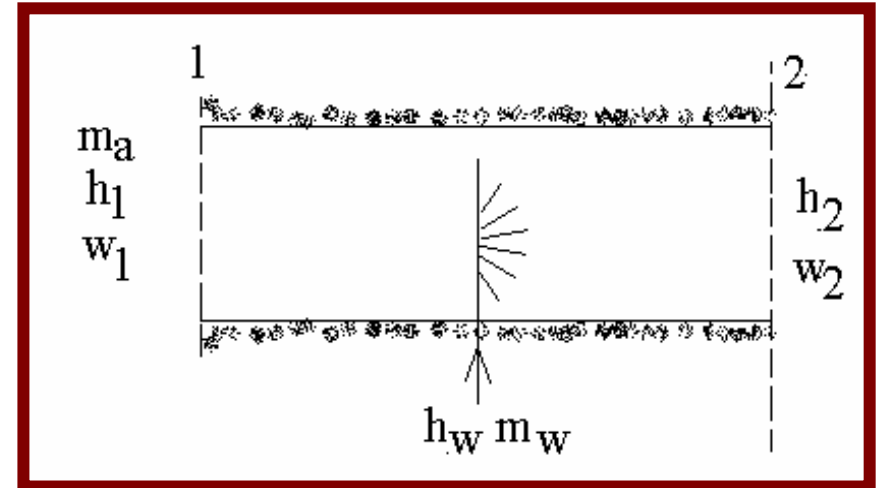



Spraying of Water(contd...)



**Moral: The final state of air leaving lies along a straight line through the initial state
Whose direction is fixed by the enthalpy of water injected**



5. Injecting steam into a stream of air



- The mathematical treatment exactly the same as though water is injected
- The value of h_w will be the enthalpy of steam
- There is problem in cases 4 and 5!
- We don't know where exactly the point 2 lies
- All that we know is the direction in which 2 lies with reference to 1.



Injecting Steam(contd...)

- On a Cartesian co-ordinate system that information would have been adequate.
- !!But, in the psychrometric chart h and w lines are not right angles!!
- **HOW TO CONSTRUCT THE LINE 1-2 FOR CASES 4 AND 5 ??**



Injecting Stream(contd...)



From the centre of the circle draw a line connecting the value of which is equal to $\frac{\Delta h}{\Delta w}$. (Note that h_w units are kJ/g of water or steam). Draw a line parallel to it through 1.

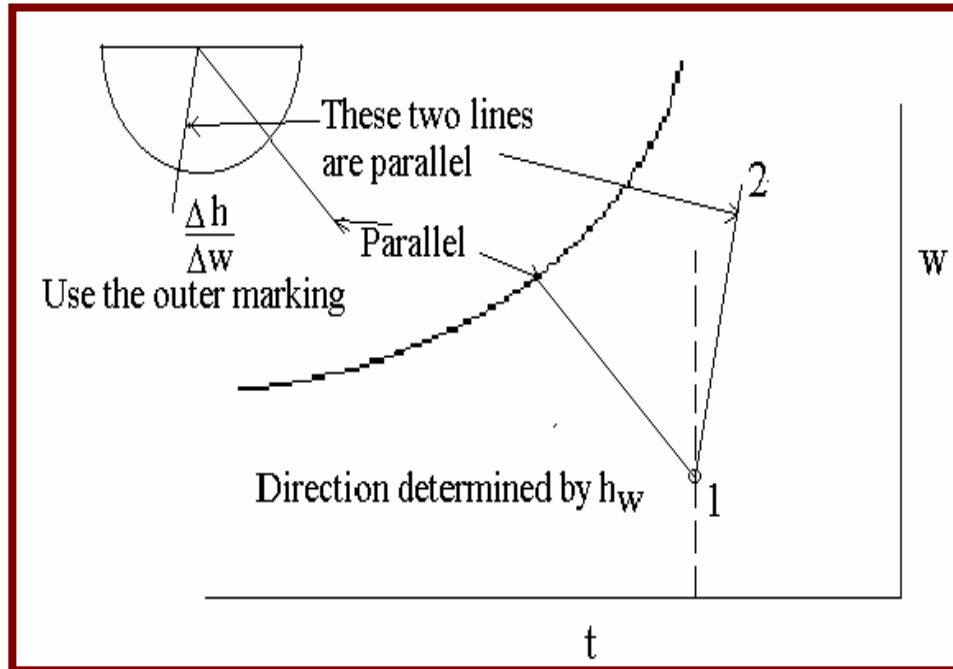



Module 4



Pure substances and
Steam tables and ideal
and real gases



Properties Of Gases

- In thermodynamics we distinguish between
 - a) perfect gases
 - b) Ideal gases
 - c) real gases
- The equation $pV/T = \text{constant}$ was derived assuming that
 - Molecules of a gas are point masses
- There are no attractive nor repulsive forces between the molecules
- **Perfect gas** is one which obeys the above equation.



Perfect Gas(contd...)

- Various forms of writing perfect gas equation of state
- $pV = mR_u T / M$ (p in Pa; V in m^3 ; m in kg; T in K; M kg/kmol)
- $pv = RT$
- $p = rRT$
- $pV = n R_u T$
- $\rho = \text{density (kg/ m}^3\text{)}$ $n = \text{number of moles}$
- $R_u = \text{Universal Gas Constant} = 8314 \text{ J/kmol K}$



Perfect Gas

(Contd...)



- $R = \text{Characteristic gas constant} = R_u/M$
 J/kg K
- $N_A = \text{Avogadro's constant} = 6.022 \times 10^{26} \text{ k}$
 mol^{-1}
- $k_B = \text{Boltzmann constant} = 1.380 \times 10^{-23} \text{ J/K}$
- $R_u = N_A k_B$



Deductions

For a perfect gas a constant pv process is also a constant temperature process; ie., it is an isothermal process.

Eg 1: *Calculate the density of nitrogen at standard atmospheric condition.*

$$p=1.013 \times 10^5 \text{ Pa}, T=288.15 \text{ K}; R=8314/28 \text{ J/kg K}$$

$$\begin{aligned} \rho &= p/RT = 1.013 \times 10^5 / [288.15 \times (8314/28)] \\ &= 1.184 \text{ kg/ m}^3 \end{aligned}$$



Perfect Gas(contd...)

Eg 2: What is the volume occupied by 1 mole of nitrogen at normal atmospheric condition?

1 mole of nitrogen has $m=0.028$ kg. $p= 1.013 \times 10^5$ Pa, $T=273.15$ K, $R=8314/28$ J/kg K

$$V = mRT/p = 0.028 \times (8314/28) \times 273.15 / 1.013 \times 10^5 = 0.0224183 \text{ m}^3$$

$$\text{Alternately } V = nr_u t/p = 1 \times 8314 \times 273.15 / 1.013 \times 10^5 = 0.0224183 \text{ m}^3$$

This is the familiar rule that a mole of a gas at NTP will occupy about 22.4 litres.

Note: NTP refers to 273.15 K and STP to 288.15 K; $P=1.013 \times 10^5$ pa



Perfect Gas(contd...)

When can a gas be treated as a perfect gas?

A) At low pressures and temperatures far from critical point

B) At low densities

➤ A perfect gas has constant specific heats.

➤ An ideal gas is one which obeys the above equation, but whose specific heats are functions of temperature alone.



Real Gas

A real gas obviously does not obey the perfect gas equation because, the molecules have a finite size (however small it may be) and they do exert forces among each other. One of the earliest equations derived to describe the real gases is the van der Waal's equation

$$(P+a/v^2)(v-b)=RT;$$

Constant a takes care of attractive forces; B the finite volume of the molecule.



Real Gas (contd...)



- There are numerous equations of state.
- The world standard to day is the Helmholtz free energy based equation of state.
- For a real gas $p v \neq RT$;
- The quantity $p v / RT = z$ and is called the “COMPRESSIBILITY”.
- For a perfect gas always $z=1$.



Definitions

- Specific heat at constant volume $c_v = (\partial u / \partial T)_v$
- enthalpy $h = u + pv$
- Specific heat at constant pressure $c_p = (\partial h / \partial T)_p$
- u , h , c_v and c_p are all properties.
- Implies partial differentiation.
- The subscript denotes whether v or p is kept constant.



Definitions (contd...)

- For a perfect gas since c_p and c_v are constants and do not depend on any other property, we can write $c_v = du/dT$ and $c_p = dh/dT$
- Since $h = u + pv$ $dh/dT = du/dT + d(pv)/dT$ 1
- But $pv = RT$ for a perfect gas. Therefore, $d(pv)/dT = d(RT)/dT = R$
- Eq. 1 can be rewritten as $c_p = c_v + R$
- R is a positive quantity. Therefore, for any perfect gas $c_p > c_v$
- Note: **Specific heats and R have the same units J/kg K**



Alternate Definitions From Physics:

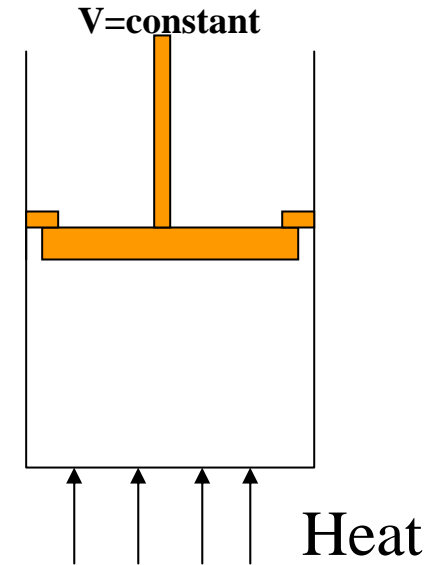
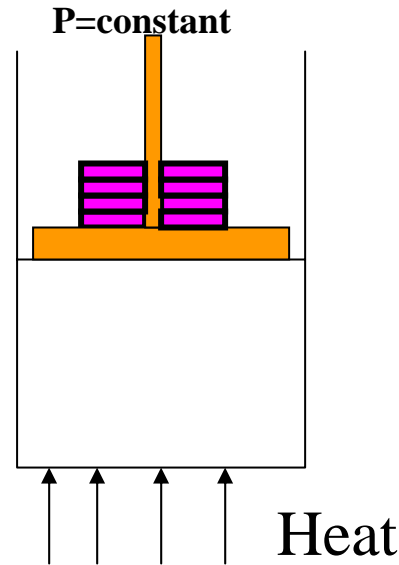
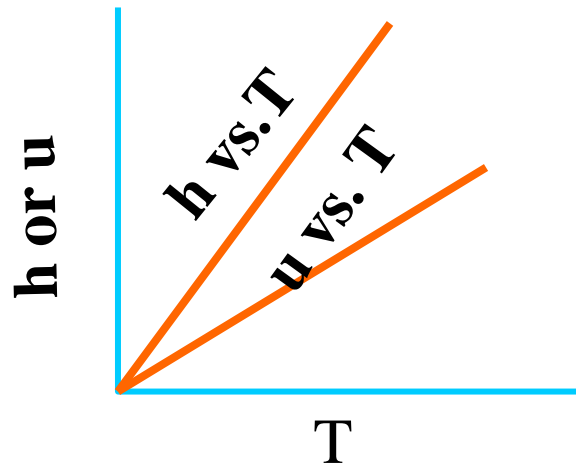

Alternate Definitions

From Physics (contd...)

➤ c_p = amount of heat to be added to raise the temperature of unit mass of a substance when the pressure is kept constant

➤ c_v = amount of heat to be added to raise the temperature of unit mass of a substance when the volume is kept constant

➤ Physical interpretation of why $c_p > c_v$?



Alternate Definitions From Physics(contd...)

➤ When heat is added at const. p , a part of it goes to raising the piston (and weights) thus doing some work. Therefore, heat to be added to rise system T by 1K must account for this. Consequently, more heat must be added than in $v=\text{const.}$ case (where the piston does not move).



Alternate Definitions From Physics (contd...)

- When heat is added at const v the whole amount subscribes to increase in the internal energy.
- The ratio c_p/c_v is designated as γ .
- c_p and c_v increase with temperature

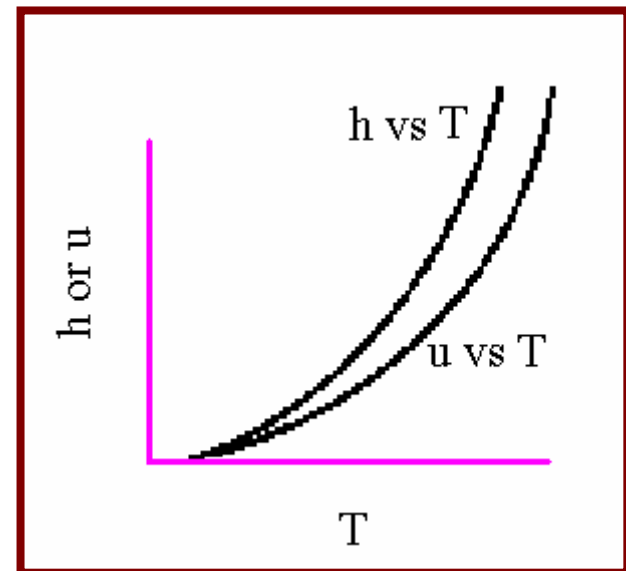



Alternate Definitions From Physics (contd...)

Volume Fractions of Components in Sea Level Dry Air
and their ratio of specific heats

		γ			γ
N ₂	0.78084	1.40	O ₂	0.209476	1.40
Ar	9.34x10 ⁻³	1.67	CO ₂	3.14x10 ⁻⁴	1.30
Ne	1.818x10 ⁻⁵	1.67	He	5.24x10 ⁻⁶	1.67
Kr	1.14x10 ⁻⁶	1.67	Xe	8.7x10 ⁻⁸	1.67
CH ₄	2x10 ⁻⁶	1.32	H ₂	5x10 ⁻⁷	1.41



Implications of an Adiabatic Process for a Perfect Gas in a Closed System



- The First Law for a closed system going through an adiabatic process is
- $-w=du$ or $-pdv=c_vdT$ for a perfect gas
- From the relation $c_p-c_v=R$ and $\gamma=c_p/c_v$
- $c_v=R/(\gamma-1)$ $c_p=R \gamma /(\gamma-1)$
- Therefore $-pdv=RdT /(\gamma-1)$ (A)
- From the perfect gas relation $pv=RT$;



Implications (Contd...)

➤ Since During an adiabatic process p, v and T can change simultaneously let dp, dv and dT be the incremental changes.

➤ Now the perfect gas relation will be

$$(p+dp)(v+dv) = R(T+dT)$$

➤ Which on expansion become $pv + vdp + pdv + dp dv = RT + RdT$



Implications (Contd...)

➤ Using the condition $p v = R T$ and the fact that product of increments $d p d v$ can be ignored in relation to the other quantities

➤ we get

$$v dp + p dv = R dT$$

➤ Substitute for $R dT$ in eq. (A)

$$-p dv = [v dp + p dv] / (\gamma - 1)$$

➤ Rearrange terms

$$-p dv \{ 1 + 1 / (\gamma - 1) \} = v dp / (\gamma - 1)$$

➤ or $-\gamma p dv = v dp$ or $-\gamma dv/v = dp/p$



Implications

(Contd...)



- We will integrate it to obtain
- $\text{const} - \gamma \ln (v) = \ln (p)$
- $\text{const} = \ln (p) + \gamma \ln (v) = \ln (p) + \ln (v^\gamma) = \ln(pv^\gamma)$
- or $pv^\gamma = \text{another constant (B)}$



Implications (Contd...)

Note: This is an idealised treatment. A rigorous treatment needs the Second Law of Thermodynamics. Eq (B) holds good when the process is also reversible. The concept of reversibility will be introduced later.

The work done during an adiabatic process between states 1-2 will be

$$W_{1-2} = (p_1 V_1 - p_2 V_2) / (g-1)$$



Implications (Contd...)



Recapitulate: $pv^\gamma = \text{constant}$

1. Is not an equation of state, but a description of the path of a specific process - adiabatic and reversible
2. Holds only for a perfect gas



Pure Substance



- Pure Substance is one with uniform and invariant chemical composition.
- Eg: Elements and chemical compounds are pure substances. (water, stainless steel)
- Mixtures are not pure substances. (eg: Humid air)



(contd)



- **Exception!! Air is treated as a pure substance though it is a mixture of gases.**
- In a majority of cases a minimum of two properties are required to define the state of a system. The best choice is an extensive property and an intensive property



Properties Of Substance



- Gibbs Phase Rule determines what is expected to define the state of a system
- $F=C+2-P$
- F = Number of degrees of freedom (i.e., no. of properties required)
- C = Number of components P = Number of phases
- E.g.: Nitrogen gas $C=1$; $P=1$. Therefore, $F=2$



(Contd...)

- To determine the state of the nitrogen gas in a cylinder two properties are adequate.
- A closed vessel containing water and steam in equilibrium:
 $P=2, C=1$
- Therefore, $F=1$. If any one property is specified it is sufficient.
- A vessel containing water, ice and steam in equilibrium
- $P=3, C=1$ therefore $F=0$. The triple point is uniquely defined.



Properties of Liquids



The most common liquid is water. It has peculiar properties compared to other liquids.

- Solid phase is less dense than the liquid phase (ice floats on water)
- Water expands on cooling (a fully closed vessel filled with water will burst if it is cooled below the freezing point).
- The largest density of water near atmospheric pressure is at 4°c.



Properties of Liquids

(contd...)



- The zone between the saturated liquid and the saturated vapour region is called the two phase region - where the liquid and vapour can co-exist in equilibrium.
- **Dryness fraction:** It is the mass fraction of vapour in the mixture.
- Normally designated by 'x'.
- On the **saturated liquid** line $x=0$
- On the **saturated vapour** line $x=1$
- x can have a value only between 0 and 1



Properties of Liquids

(contd...)

- Data tables will list properties at the two ends of saturation.
- To calculate properties in the two-phase region:
- p, T will be the same as for saturated liquid or saturated vapour

$$v = x v_g + (1-x) v_f$$

$$h = x h_g + (1-x) h_f$$

$$u = x u_g + (1-x) u_f$$



Properties of Liquids

(contd...)

- One of the important properties is the change in enthalpy of phase transition h_{fg} also called the latent heat of vaporisation or latent heat of boiling. It is equal to $h_g - h_f$.
- Similarly u_{fg} - internal energy change due to evaporation and v_{fg} - volume change due to evaporation can be defined (but used seldom).



Properties of Liquids

(contd...)



➤ The saturation phase depicts some very interesting properties:

➤ The following saturation properties depict a maximum:

1. T ρ_f 2. T ($\rho_f - \rho_g$) 3. T h_{fg} 4. $T_c(p_c - p)$

5. $p(T_c - T)$ 6. $p(v_g - v_f)$ 7. T ($\rho_c^2 - \rho_f \rho_g$) 8. h_g

➤ The equation relating the pressure and temperature along the saturation is called the vapour pressure curve.

➤ Saturated liquid phase can exist only between the triple point and the critical point.



Characteristics of the critical point



1. It is the highest temperature at which the liquid and vapour phases can coexist.
 2. At the critical point h_{fg} , u_{fg} and v_{fg} are zero.
 3. Liquid vapour meniscus will disappear.
 4. Specific heat at constant pressure is infinite.
- A majority of engineering applications (eg: steam based power generation; Refrigeration, gas liquefaction) involve thermodynamic processes close to saturation.



Characteristics of the critical point (contd...)



- The simplest form of vapour pressure curve is
- $\ln p = A + B/T$ valid only near the triple point. (Called Antoine's equation)
- The general form of empirical vapour pressure curve is
- $\ln p = \ln p_c + [A_1(1 - T/T_c) + A_2(1 - T/T_c)^{1.5} + A_3(1 - T/T_c)^2 + \dots] / (T/T_c)$ (Called the Wagner's equation)
- Definitions: Reduced pressure $p_r = p/p_c$;
- Reduced temperature $T_r = T/T_c$



Characteristics of the critical point (contd...)

- For saturated phase often it enthalpy is an important property.
- Enthalpy-pressure charts are used for refrigeration cycle analysis.
- Enthalpy-entropy charts for water are used for steam cycle analysis.
- **Note:** Unlike pressure, volume and temperature which have specified numbers associated with it, in the case of internal energy, enthalpy (and entropy) only changes are required. Consequently, a base (or datum) is defined - as you have seen in the case of water.



Characteristics of the critical point (contd...)



- For example for NIST steam tables $u=0$ for water at triple point. (You can assign any number you like instead of 0). [Don't be surprised if two two different sets of steam tables give different values for internal energy and enthalpy].
- Since, p and v for water at triple point are known you can calculate h for water at triple point (it will not be zero).
- If you like you can also specify $h=0$ or 200 or 1000 kJ/kg at the triple point and hence calculate u .

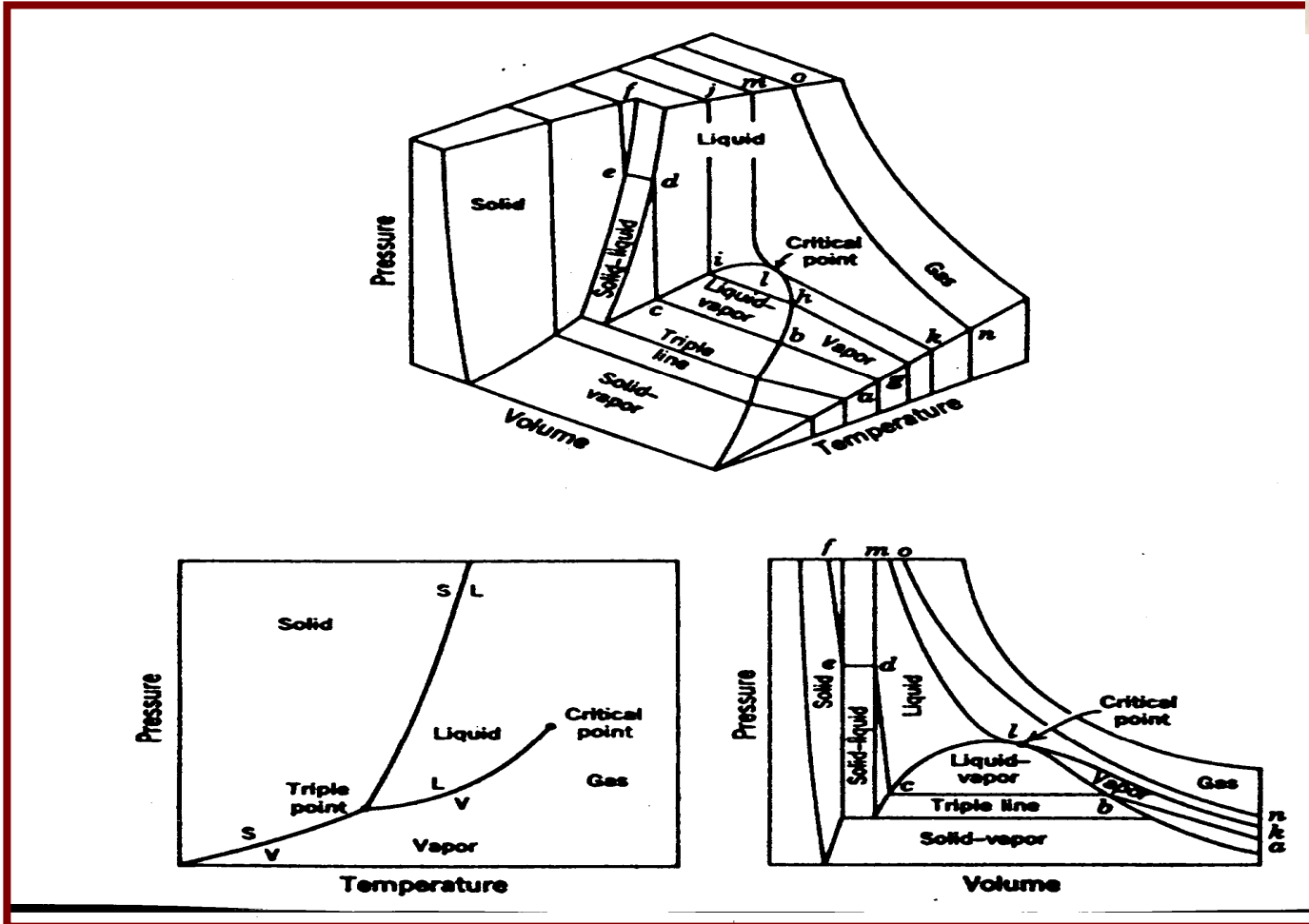

**Pressure-volume-temperature surface
for a substance that contracts on freezing**

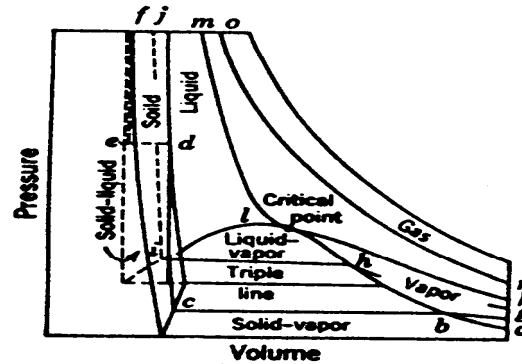
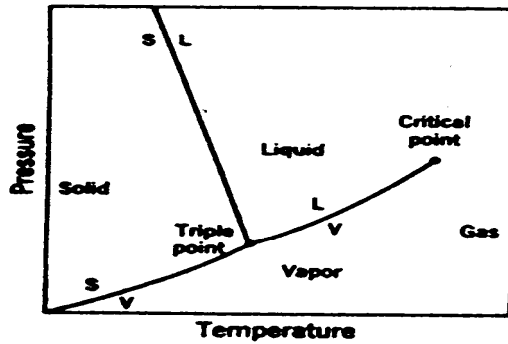
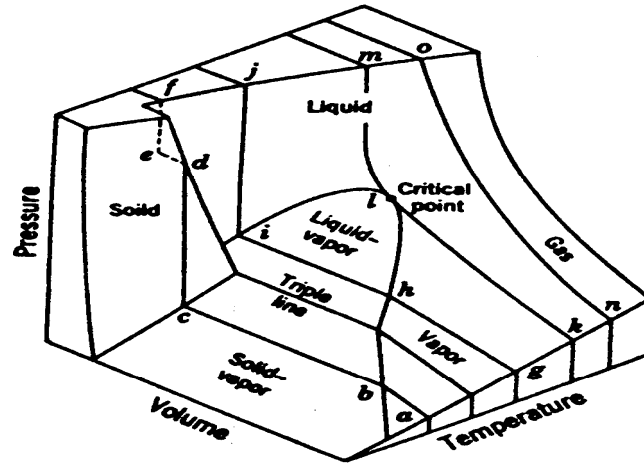

Pressure-volume-temperature surface for a substance that expands on freezing.

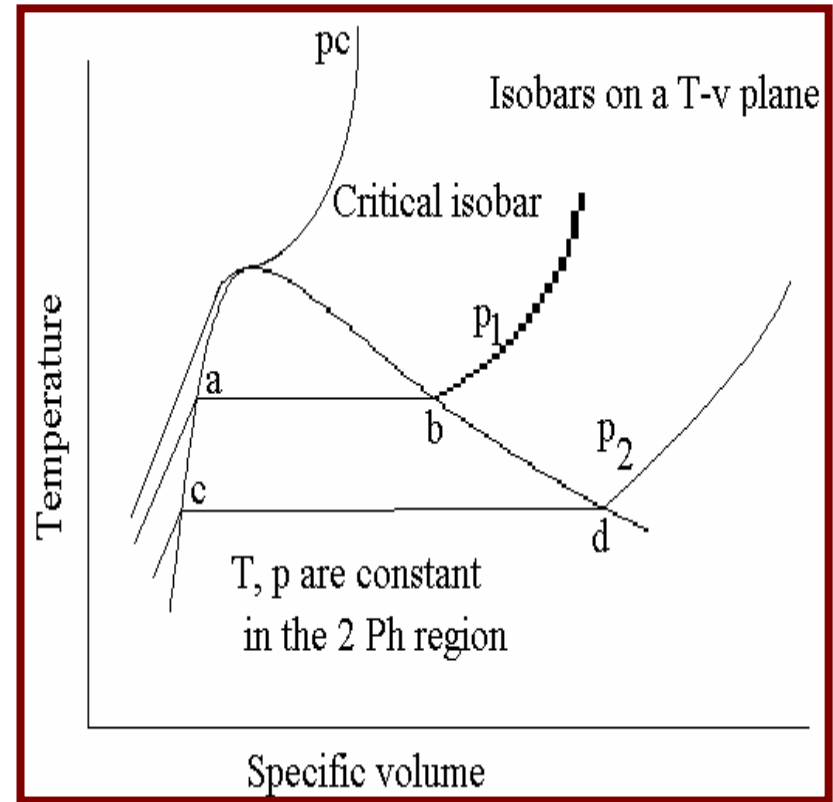
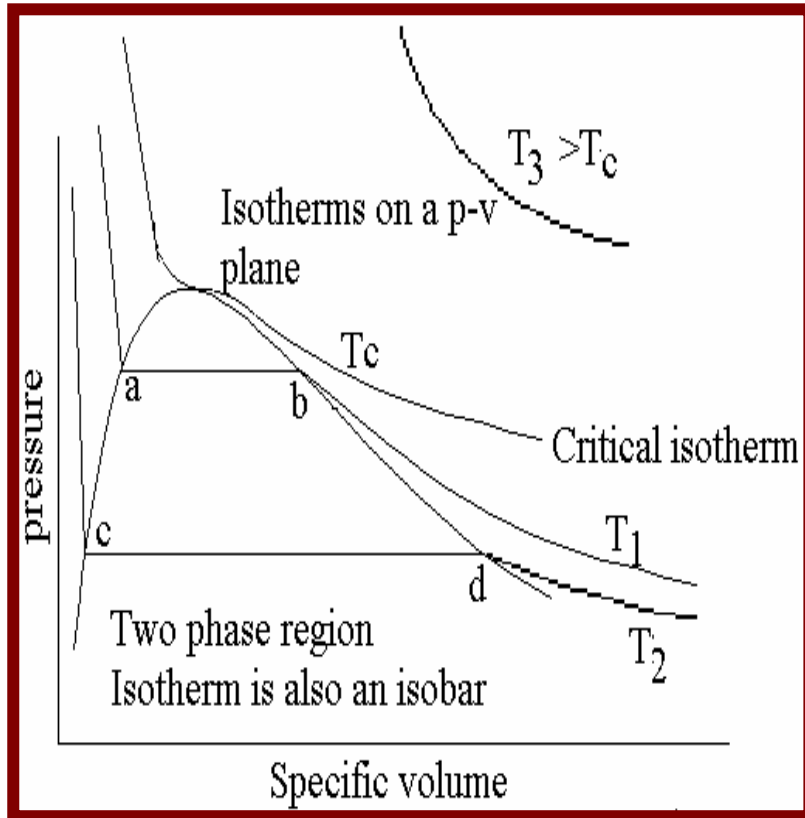

Note that there is a discontinuity at the phase boundaries
(points a,b,c,d etc.)

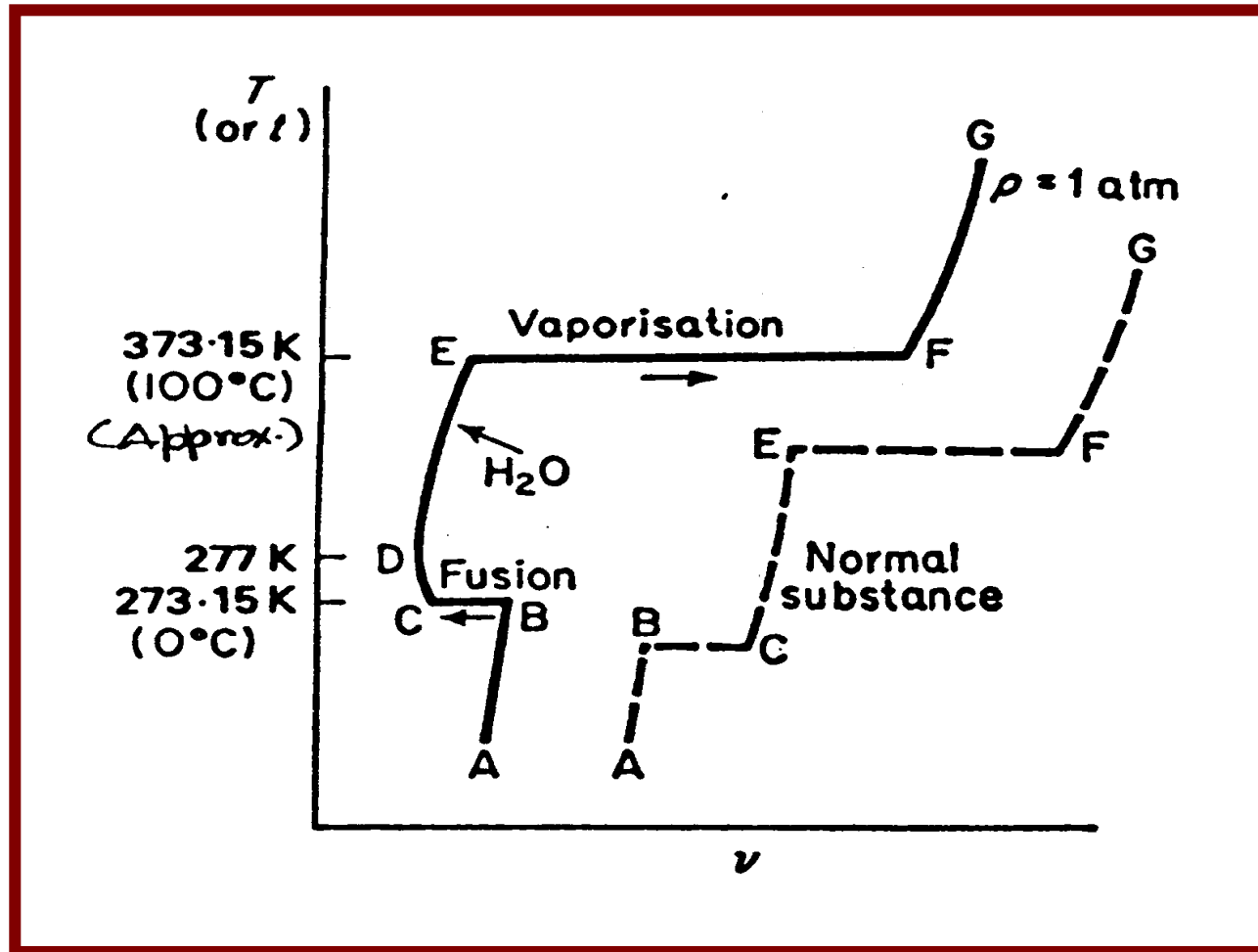

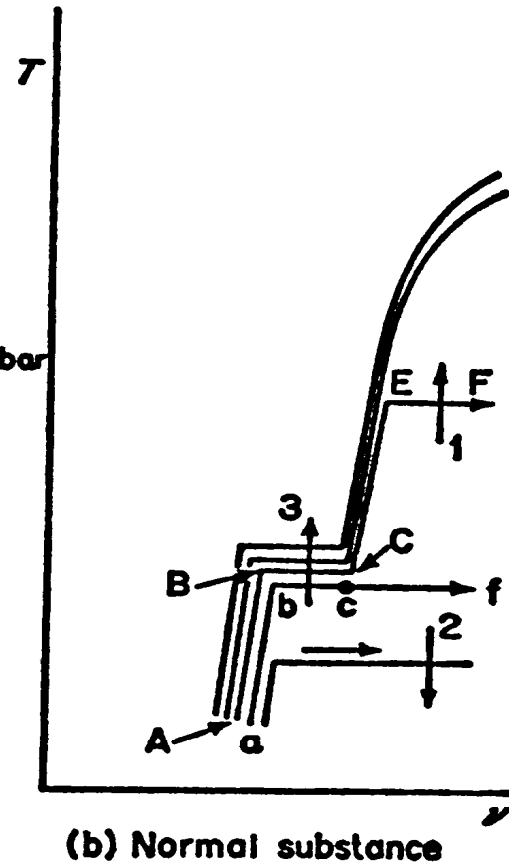
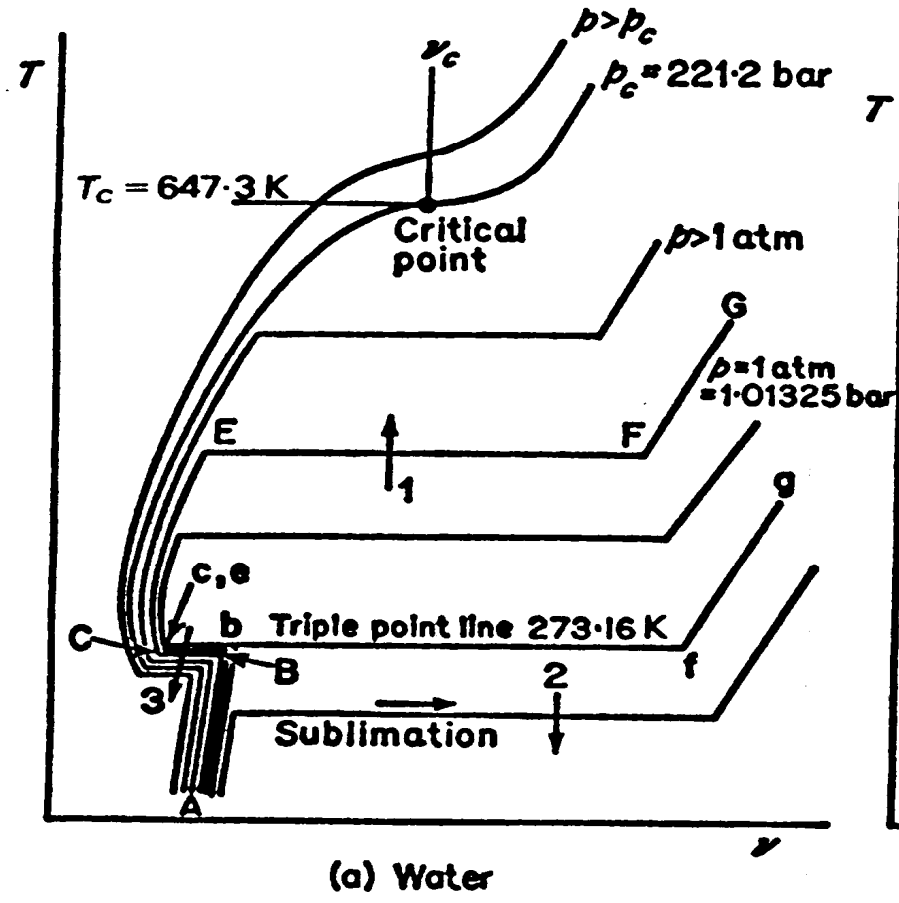

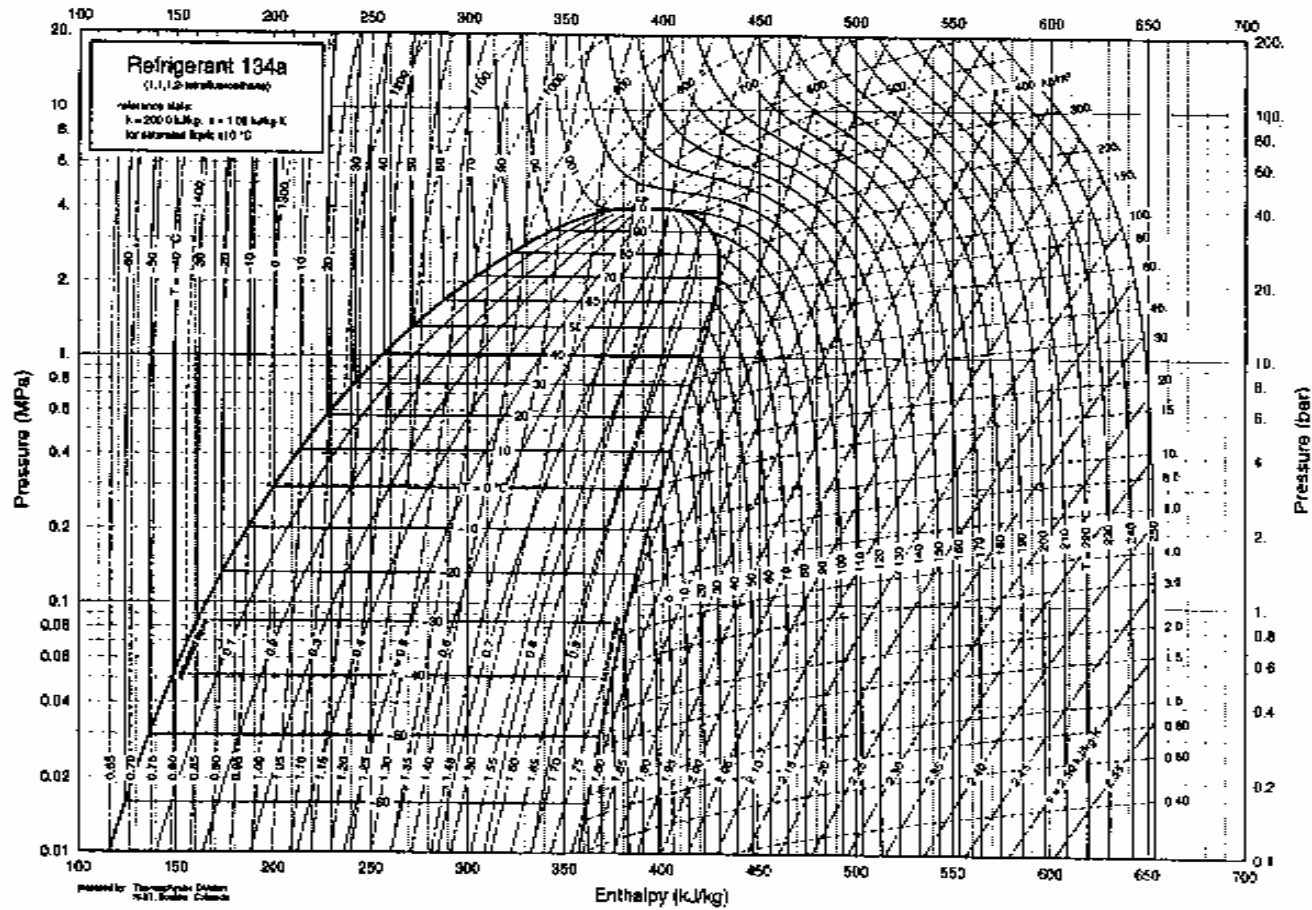



International Association for the Properties of Water and Steam (IAPWS) has provided two formulations to calculate the thermodynamic properties of ordinary water substance,

- i) “The IAPWS Formulation 1995 for the Thermodynamic Properties of Ordinary Water Substance for General and Scientific Use” (IAPWS-95) and
- ii) “The IAPWS Industrial Formulation 1997 for the Thermodynamic Properties of Water and Steam” (IAPWS-IF97).



Module 5

Basics of energy conversation cycles



Heat Engines and Efficiencies



- The objective is to build devices which receive heat and produce work (like an aircraft engine or a car engine) or receive work and produce heat (like an air conditioner) in a sustained manner.
- All operations need to be cyclic. The cycle comprises of a set of processes during which one of the properties is kept constant (V, p, T etc.)



Heat Engines(contd...)



- A minimum of 3 such processes are required to construct a cycle.
- All processes need not have work interactions (eg: isochoric)
- All processes need not involve heat interactions either (eg: adiabatic process).



Heat Engines (Contd...)

- A cycle will consist of processes: involving some positive work interactions and some negative.
- If sum of +ve interactions is $>$ -ve interactions the cycle will produce work
- If it is the other way, it will need work to operate.
- On the same lines some processes may have +ve and some -ve heat interactions.



Heat Engines (Contd...)

- Commonsense tells us that to return to the same point after going round we need at one path of opposite direction.
- I law does not forbid all heat interactions being +ve nor all work interactions being -ve.
- But, we know that you can't construct a cycle with all +ve or
- All -ve Q's nor with all +ve or all -ve W's
- Any cycle you can construct will have some processes with
- Q +ve some with -ve.



Heat Engines (Contd...)



- Let $Q_1, Q_3, Q_5 \dots$ be +ve heat interactions (Heat supplied)
- $Q_2, Q_4, Q_6 \dots$ be -ve heat interactions (heat rejected)
- From the first law we have
- $Q_1 + Q_3 + Q_5 \dots - Q_2 - Q_4 - Q_6 \dots = \text{Net work delivered } (W_{\text{net}})$
- $\Sigma Q_{+\text{ve}} - \Sigma Q_{-\text{ve}} = W_{\text{net}}$
- The efficiency of the cycle is defined as $\eta = W_{\text{net}} / \Sigma Q_{+\text{ve}}$
- **Philosophy → What we have achieved ÷ what we have spent to achieve it**



Heat Engines (Contd...)

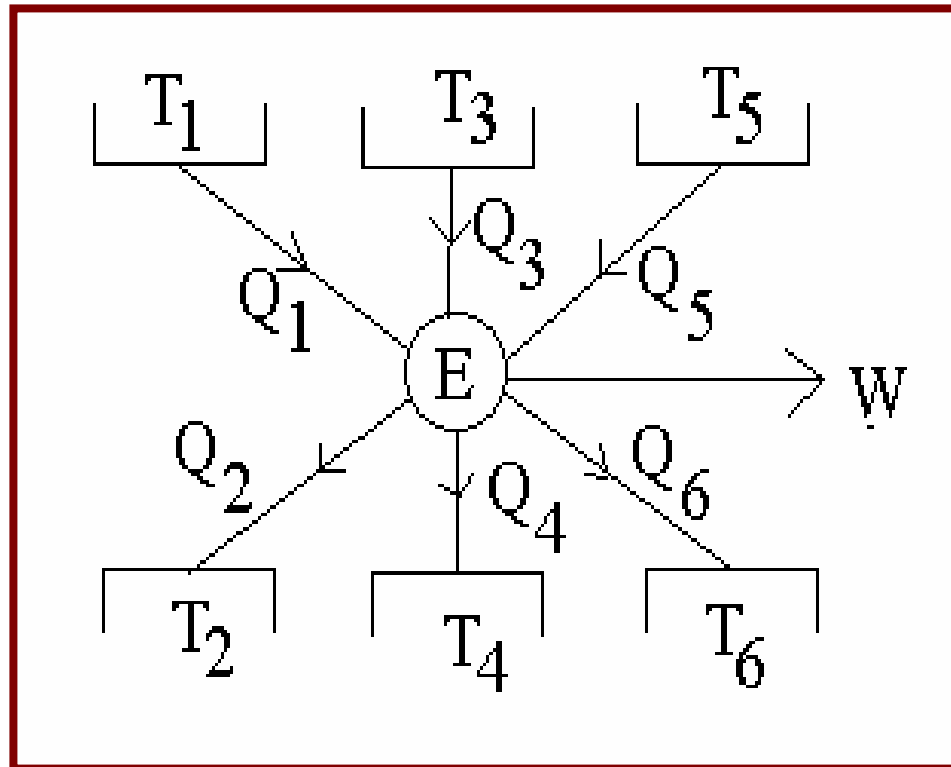



Consider the **OTTO Cycle** (on which your car engine works)

It consists of two isochores and two adiabatics

- There is no heat interaction during 1-2 and 3-4
- Heat is added during constant volume heating (2-3) $Q_{2-3} = c_v (T_3 - T_2)$
- Heat is rejected during constant volume cooling (4-1) $Q_{4-1} = c_v (T_1 - T_4)$
- Which will be negative because $T_4 > T_1$

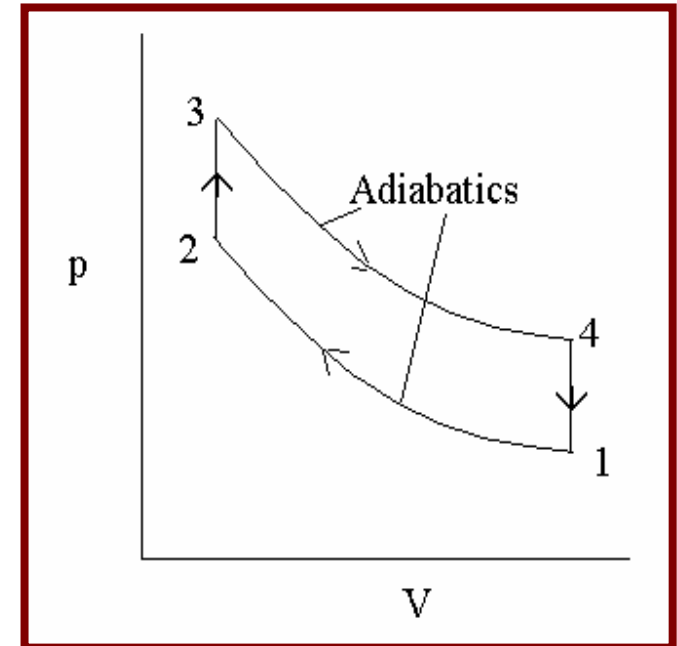



- Work done = $c_v (T_3 - T_2) + c_v (T_1 - T_4)$
- The efficiency = $\frac{[c_v(T_3 - T_2) + c_v(T_1 - T_4)]}{[c_v(T_3 - T_2)]}$
 $= \frac{[(T_3 - T_2) + (T_1 - T_4)]}{[(T_3 - T_2)]}$
 $= 1 - \frac{(T_4 - T_1)}{(T_3 - T_2)}$



Consider a **Carnot cycle** - against which all other cycles are compared

It consists of two isotherms and two adiabatics

- Process 4-1 is heat addition because $v_4 < v_1$
- Process 2-3 is heat rejection because $v_3 < v_2$

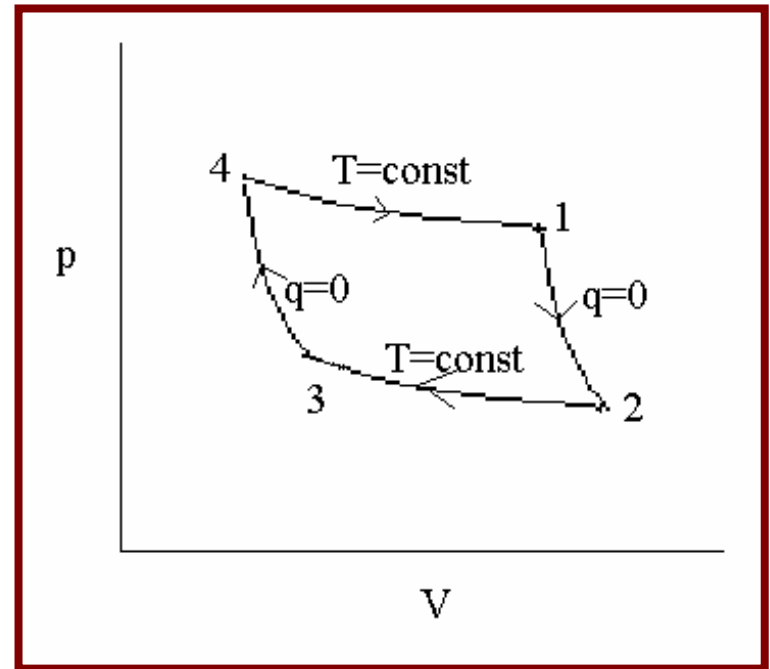



<u>Process</u>	<u>Work</u>	<u>Heat</u>
1-2	$(p_1v_1 - p_2v_2)/(g-1)$	0
2-3	$p_2v_2 \ln (v_3/v_2)$	$p_2v_2 \ln (v_3/v_2)$
3-4	$(p_3v_3 - p_4v_4)/(g-1)$	0
4-1	$p_4v_4 \ln (v_1/v_4)$	$p_4v_4 \ln (v_1/v_4)$
Sum	$(p_1v_1 - p_2v_2 + p_3v_3 - p_4v_4)/(g-1)$	
	$+ RT_2 \ln (v_3/v_2)$	$RT_2 \ln (v_3/v_2)$
	$+ RT_1 \ln (v_1/v_4)$	$+ RT_1 \ln (v_1/v_4)$ But,
	$p_1v_1 = p_4v_4$ and $p_2v_2 = p_3v_3$	

Therefore the first term will be 0

!!We reconfirm that I law works!!



We will show that $(v_2/v_3) = (v_1/v_4)$

1 and 2 lie on an adiabat

so do 3 and 4

$$p_1 v_1^\gamma = p_2 v_2^\gamma$$

$$p_4 v_4^\gamma = p_3 v_3^\gamma$$

Divide one by the other
 $/p_3 v_3^\gamma$ (A)

$$(p_1 v_1^\gamma / p_4 v_4^\gamma) = (p_2 v_2^\gamma / p_3 v_3^\gamma)$$

$$(p_1/p_4) (v_1^\gamma / v_4^\gamma) = (p_2/p_3) (v_2^\gamma / v_3^\gamma)$$

But $(p_1/p_4) = (v_4/v_1)$ because 1 and 4 are on the same isotherm

Similarly $(p_2/p_3) = (v_3/v_2)$ because 2 and 3 are on the same isotherm



Therefore A becomes

$$(v_1 / v_4)^{\gamma-1} = (v_2/v_3)^{\gamma-1}$$

which means

$$(v_2/v_3) = (v_1/v_4)$$

Work done in Carnot cycle = $RT_1 \ln (v_1/v_4) + RT_2 \ln (v_3/v_2)$

$$= RT_1 \ln (v_1/v_4) - RT_2 \ln (v_2/v_3)$$

$$= R \ln (v_1/v_4) (T_1 - T_2)$$

Heat supplied = $R \ln (v_1/v_4) T_1$

The efficiency = $(T_1 - T_2)/T_1$

In all the cycles it also follows that Work done = Heat supplied
- heat rejected



Carnot engine has one Q +ve process and one Q -ve process. This engine has a single heat source at T_1 and a single sink at T_2 .

If Q +ve $>$ Q -ve; W will be +ve

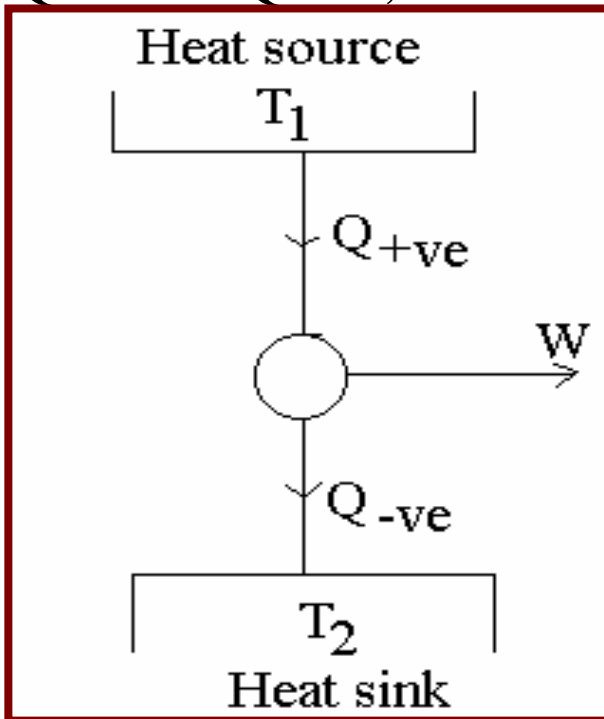

It is a heat engine

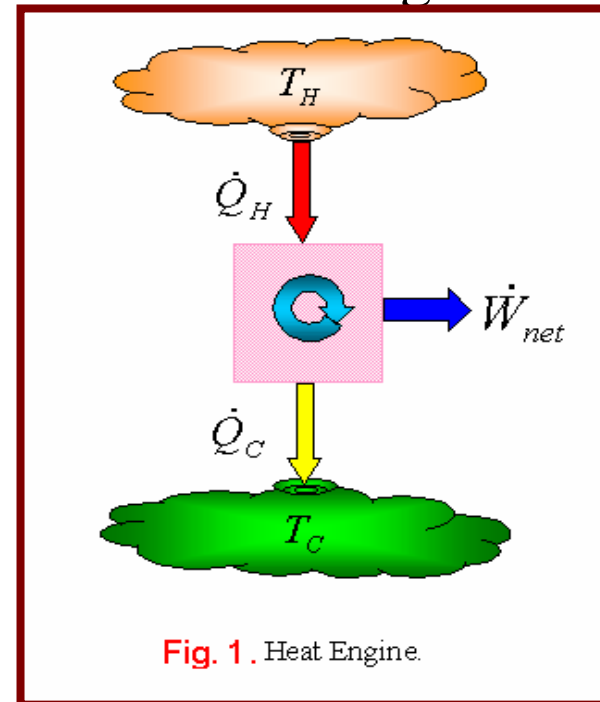

Fig. 1. Heat Engine.



It will turn out that Carnot efficiency of $(T_1 - T_2)/T_1$ is the best we can get for any cycle operating between two fixed temperatures.



$Q_{+ve} < Q_{-ve}$ W will be -ve It is not a heat engine

Efficiency is defined only for a work producing heat engine
not a work consuming cycle

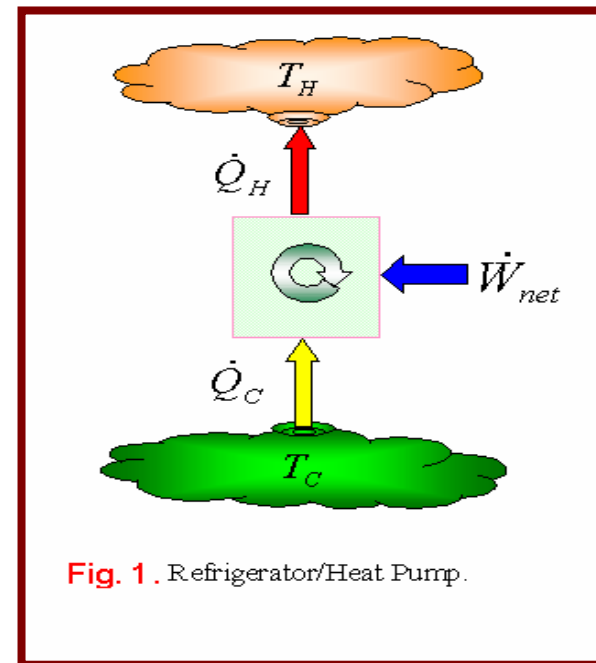
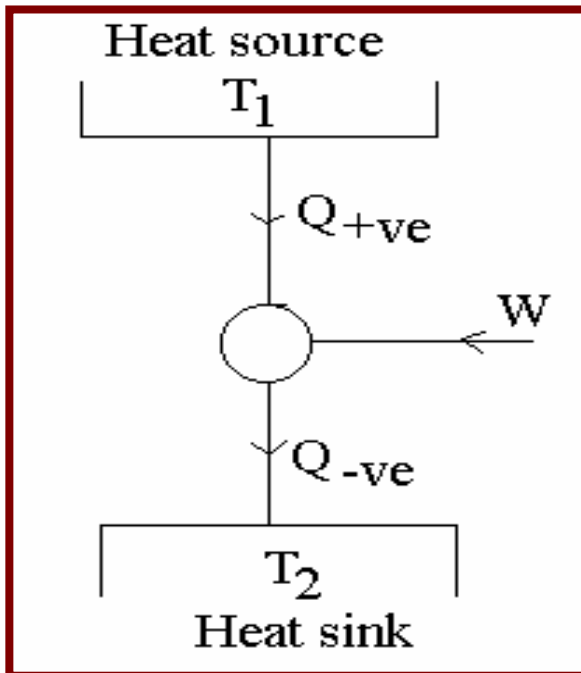

Fig. 1. Refrigerator/Heat Pump.



Note: We can't draw such a diagram for an Otto cycle because there is no single temperature at which heat interactions occur



Chapter 6



Leads Up To Second Law Of Thermodynamics



It is now clear that we can't construct a heat engine with just one +ve heat interaction.

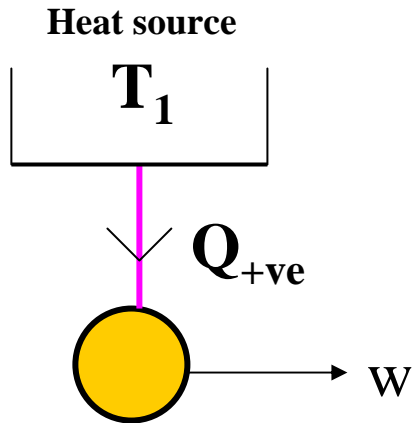

Perpetual motion machine of the first kind violates I LAW (It produces work without receiving heat)

The above engine is not possible.
Perpetual motion machine of the second kind is not possible.



Is it possible to construct a heat engine with only one -ve heat interaction? Is the following engine possible?

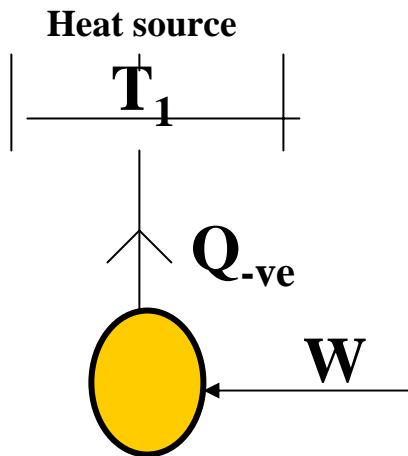

The answer is yes, because This is what happens in a stirrer

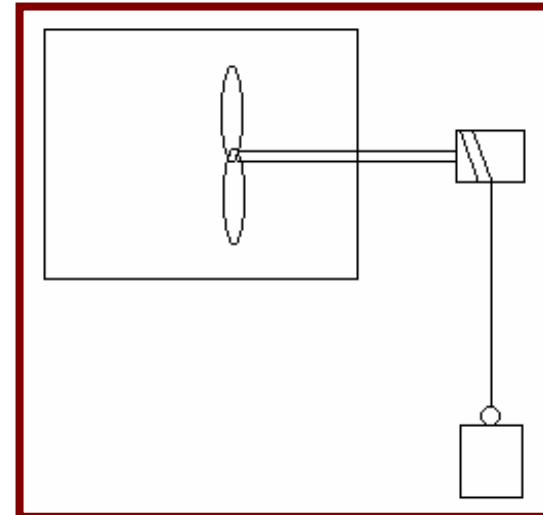
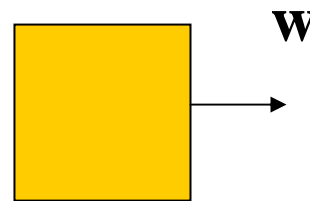



Enunciation of II Law of Thermodynamics

Statement 1: It is impossible to construct a device which operating in a cycle will produce no effect other than raising of a weight and exchange of heat with a single reservoir.

Note the two underlined words.

II Law applies only for a cycle - not for a process!! (We already know that during an isothermal process the system can exchange heat with a single reservoir and yet deliver work)

!!There is nothing like a 100% efficient heat engine!!



❖ To enunciate the II law in a different form

- !!! We have to appreciate some ground realities !!!
- All processes in nature occur unaided or spontaneously in one direction. But to make the same process go in the opposite direction one needs to spend energy.



Common sense tells us that



1. Heat flows from a body at higher temperature to a body at lower temperature

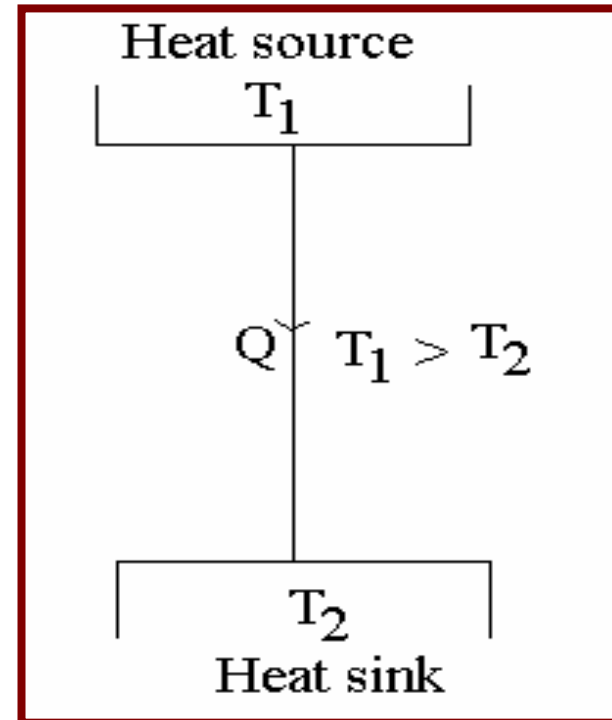
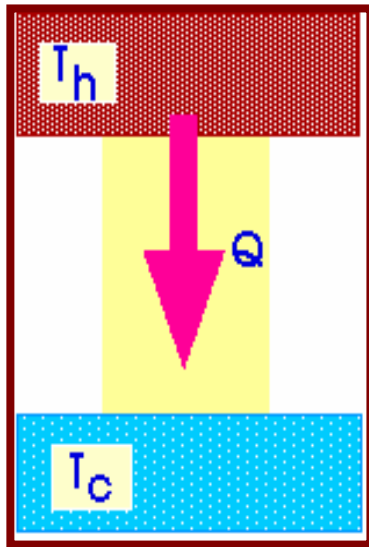

Possible



1. A hot cup of coffee left in a room becomes cold. We have to expend energy to rise it back to original temperature

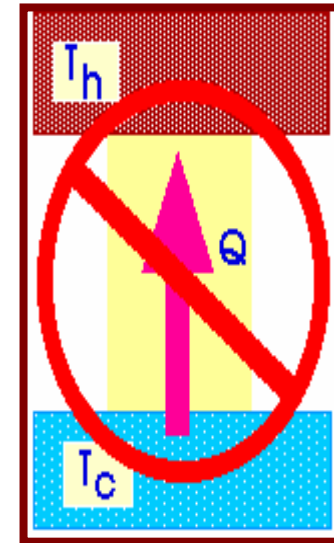
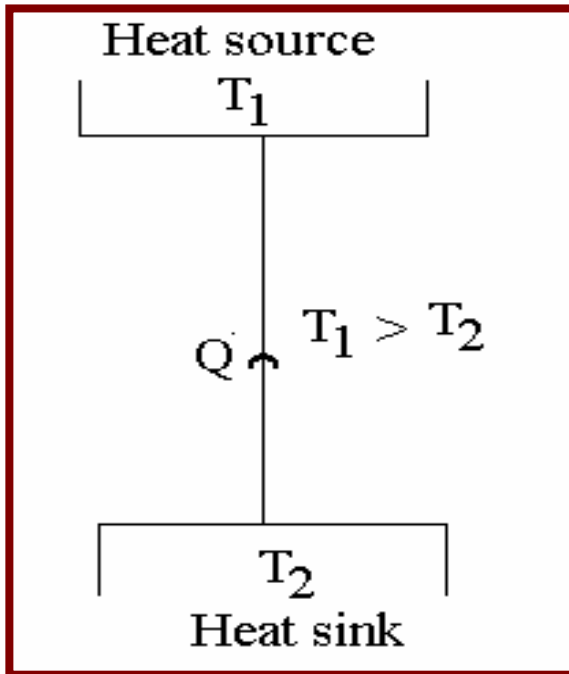

Not possible

(you can't make room heat up your coffee!!)



2. Fluid flows from a point of higher pressure or potential. to a lower one

Water from a tank can flow down
To get it back to the tank you have to use a pump i.e, you spend energy

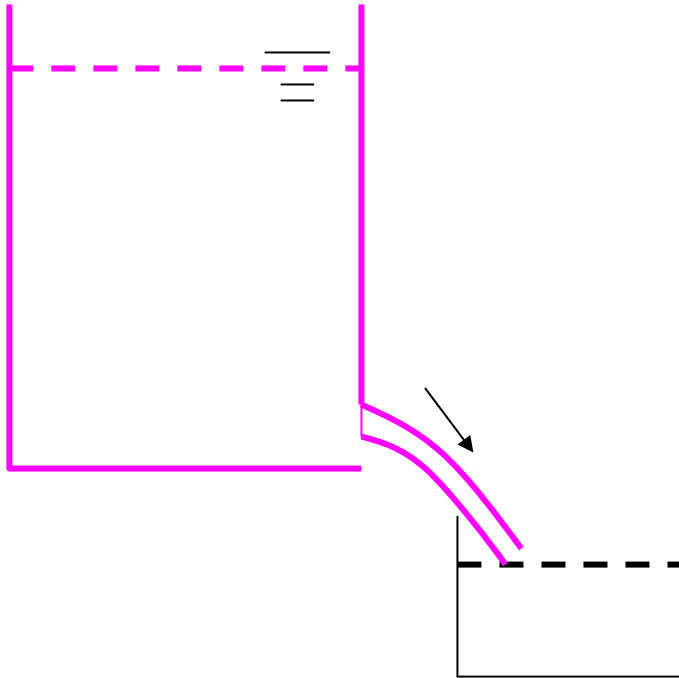

Possible

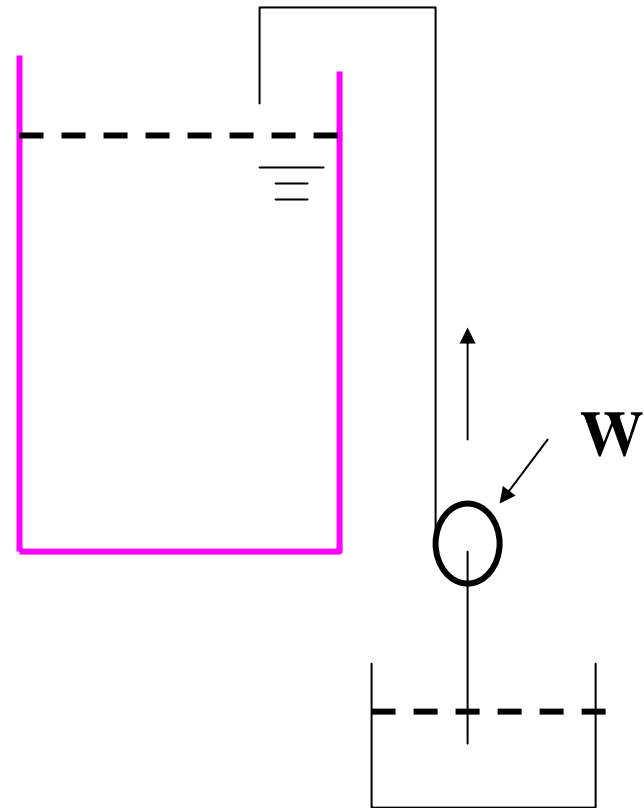



3. Current flows from a point of higher potential to lower one Battery can discharge through a resistance, to get the charge
4. You can mix two gases or liquids. But to separate them you have to spend a lot of energy. (You mix whisky and soda without difficulty - but can't separate the two - Is it worthwhile?)
5. All that one has to say is "I do". To get out of it one has to spend a lot of money
6. You can take tooth paste out of the tube but can't push it back!!



❖ Moral :

All processes such as 1-7 occur unaided in one direction but to get them go in the other direction there is an expenditure - money, energy, time, *peace of mind*?



Definitions of Reversible Process

❖ A process is reversible if after it, means can be found to restore the system and surroundings to their initial states.

Some reversible processes:

➤ Constant volume and constant pressure heating and cooling - the heat given to change the state can be rejected back to regain the state.



- Isothermal and adiabatic processes -the work derived can be used to compress it back to the original state
- Evaporation and condensation
- Elastic expansion/compression (springs, rubber bands)
- ❖ *Lending money to a friend (who returns it promptly)*



Some Irreversible Process



motion with friction

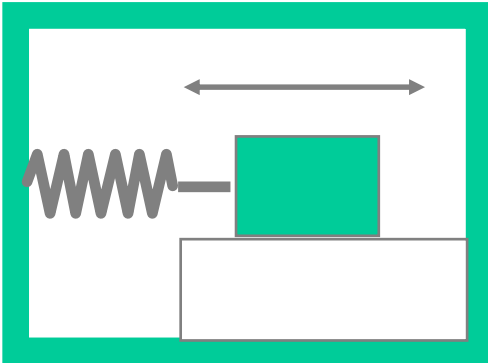

spontaneous
chemical reaction

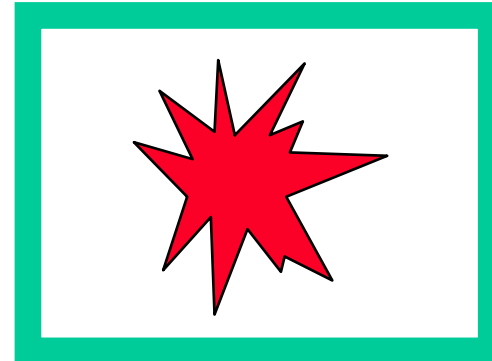

heat transfer

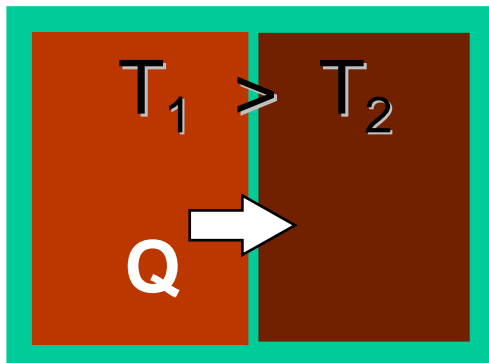

unrestrained
expansion

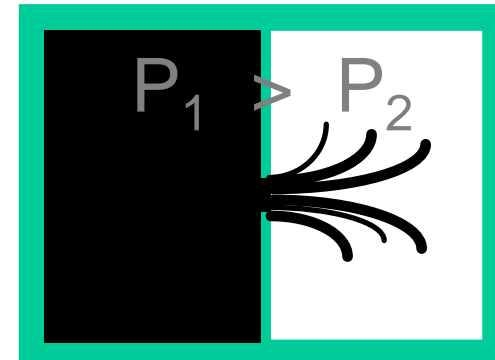



mixing



Flow of current through a resistance - when a battery discharges through a resistance heat is dissipated. You can't recharge the battery by supplying heat back to the resistance element!!

Pickpocket

!!!Marriage!!!!



➤ A cycle consisting of all reversible processes is a reversible cycle. Even one of the processes is irreversible, the cycle ceases to be reversible.

Otto, Carnot and Brayton cycles are all reversible.

A reversible cycle with clockwise processes produces work with a given heat input. The same while operating with counter clockwise processes will reject the same heat with the same work as input.



Other reversible cycles:

Diesel cycle

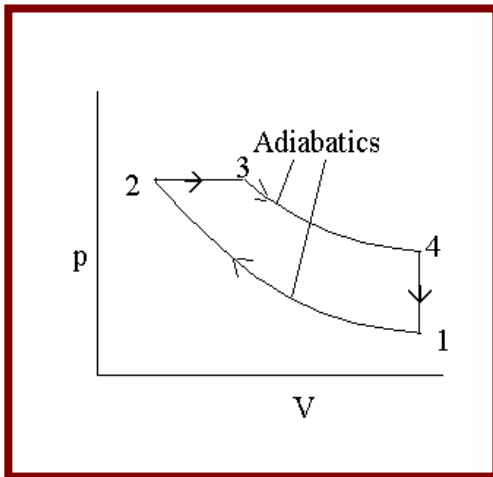

Ericsson cycle

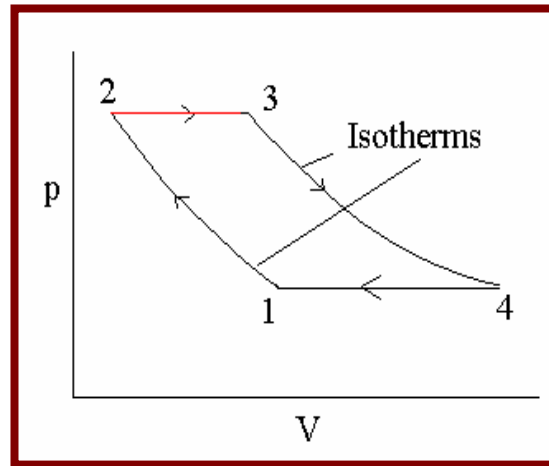

Stirling cycle

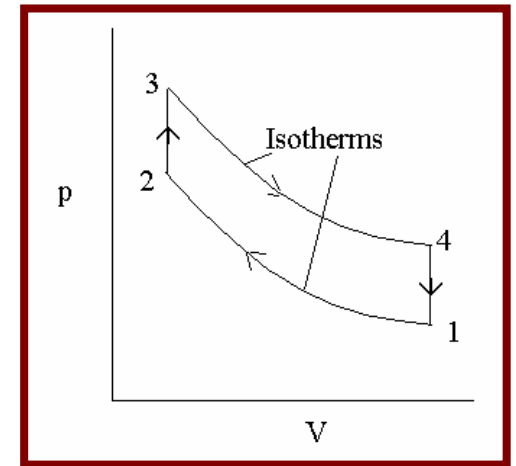



Clausius Statement of II Law of Thermodynamics

It is impossible to construct a device which operates in a cycle and produces no effect other than the transfer of heat from a cooler body to a hotter body.

❖ Yes, you can transfer heat from a cooler body to a hotter body by expending some energy.



- *Note : It is not obligatory to expend work, even thermal energy can achieve it.*
- Just as there is maximum +ve work output you can derive out of a heat engine, there is a minimum work you have to supply (-ve) to a device achieve transfer of thermal energy from a cooler to a hotter body.



Carnot Cycle for a Refrigerator/heat Pump

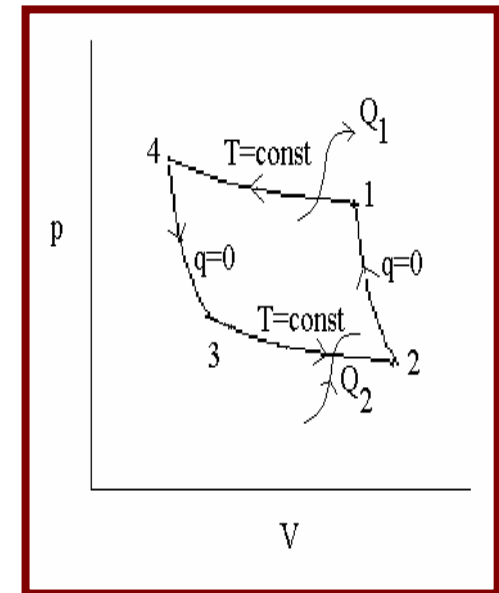
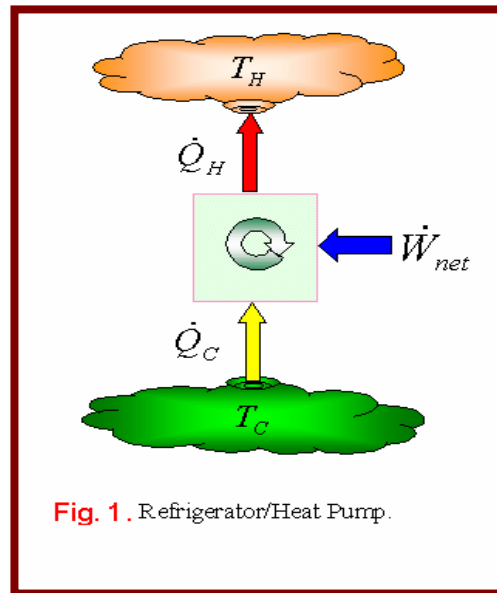
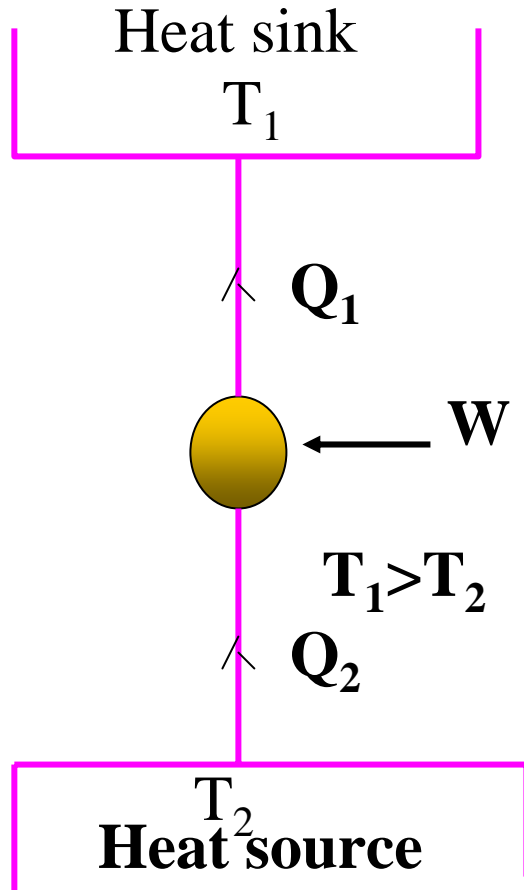

$$T_H = T_1$$

$$T_C = T_2$$



❖ *A device which transfers heat from a cooler to a warmer body (by receiving energy) is called a heat pump.* A refrigerator is a special case of heat pump.

Just as efficiency was defined for a heat engine, for a heat pump the coefficient of performance (cop) is a measure of how well it is doing the job.



❖ A heat pump

- **Invoke the definition:** what we have achieved , what we spent for it
- $\text{COP}_{\text{HP}} = \text{heat given out} , \text{work done} = \frac{1}{2}Q_1 / W^{1/2}$
- **Note :** The entity of interest is how much heat could be realised. Work is only a penalty.



Reverse cycle air conditioners used for winter heating do the above. Heat from the ambient is taken out on a cold day and put into the room.

The heat rejected at the sink is of interest in a heat pump , ie., Q_1 .

In a refrigerator the entity of interest is Q_2 .

In this case $COP_R = | Q_2/W |$

NOTE: η , COP_{HP} COP_R are all positive numbers $\eta < 1$ but COPs can be $>$ or < 1



Relation between η and COP_{HP}

It is not difficult to see that $\eta \text{ COP}_{\text{HP}} = 1$

Apply I law to Carnot cycle as a heat pump/refrigerator:

$$-Q_1 + Q_2 = -W \quad \text{or} \quad Q_1 = Q_2 + W$$

Divide both sides with W

$$Q_1 / W = Q_2 / W + 1$$

or

$$\text{COP}_{\text{HP}} = \text{COP}_{\text{R}} + 1$$

The highest COP_{HP} obtainable therefore will be $T_1 / (T_1 - T_2)$

and highest COP_{R} obtainable therefore will be $T_2 / (T_1 - T_2)$



Eg: If 10 kw of heat is to be removed from a cold store at -20°C and rejected to ambient at 30°C.

$$\text{COP}_R = 253.15 / (303.15 - 253.15) = 5.063$$

$$W = Q_2 / \text{COP}_R ; Q_2 = 10 \text{ kW}$$

$$\text{Therefore } W = 10 / 5.063 = 1.975 \text{ kW}$$

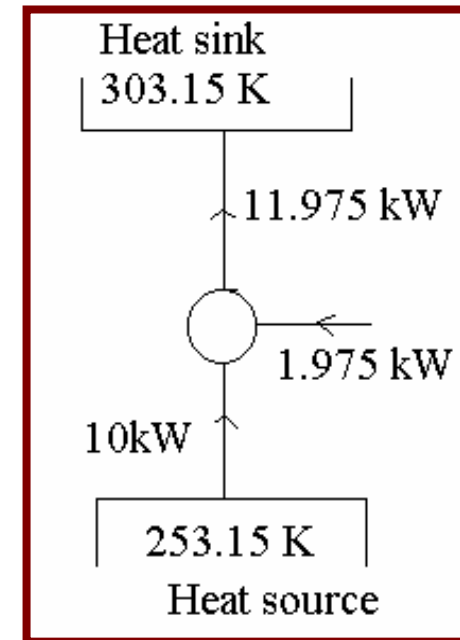



❖ **Another example:** Let us say that the outside temperature on a hot summer day is 40°C. We want a comfortable 20°C inside the room. If we were to put a 2 Ton (R) air conditioner, what will be its power consumption?

Answer: 1 Ton (R) = 3.5 kw. Therefore $Q_2=7$ kW

$COP_R = 293.15 / (313.15 - 293.15) = 14.66$ ie., $W = 7 / 14.66 = 0.47$ kW

Actually a 2 Ton air-conditioner consumes nearly 2.8 kW (much more than an ideal cycle!!)

Ideal but possible

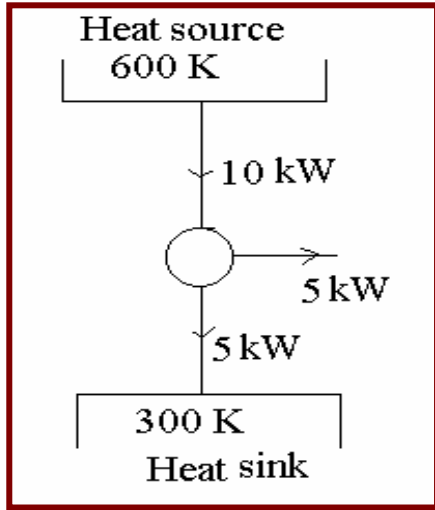

Real and possible

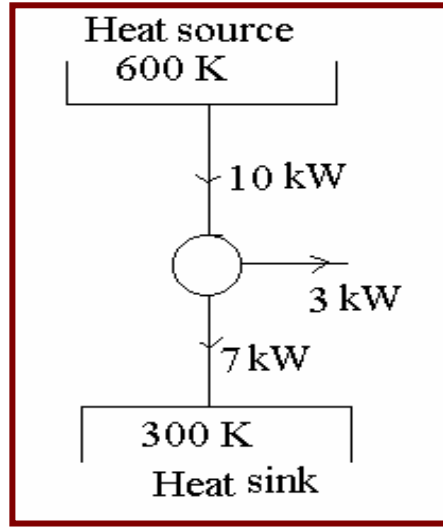

Not possible

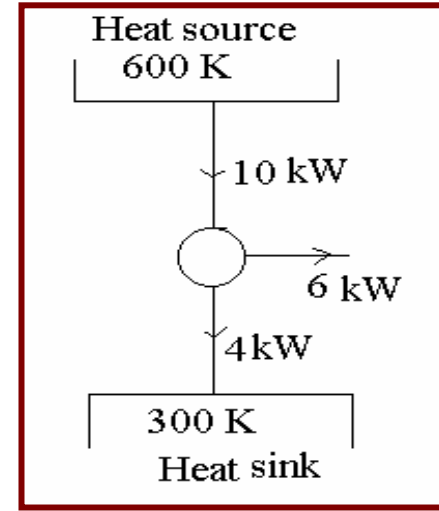

HEAT ENGINE

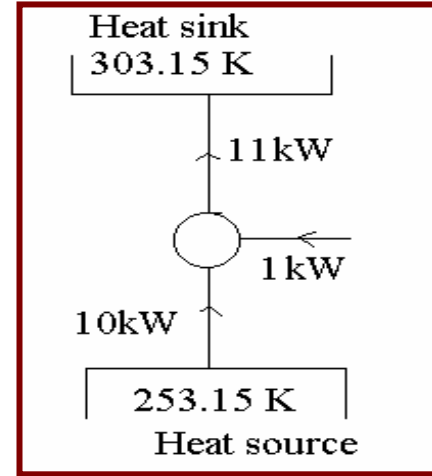
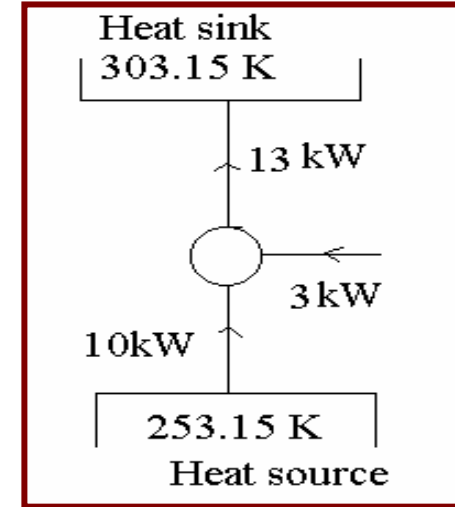
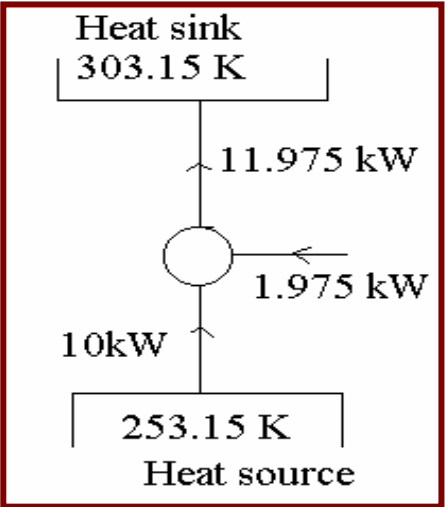

HEAT PUMP

This is the best that can happen

This is what happens in reality

You derive work > what is thermodynamic maximum nor can
You expend work < what is thermodynamic minimum



Suppose the ambient is at 300 K. We have heat sources available at temperatures greater than this say 400, 500, 600.....K. How much work can you extract per kW of heat ? Similarly, let us say we have to remove 1 kW of heat from temperatures 250, 200, 150 K. How much work should we put in?

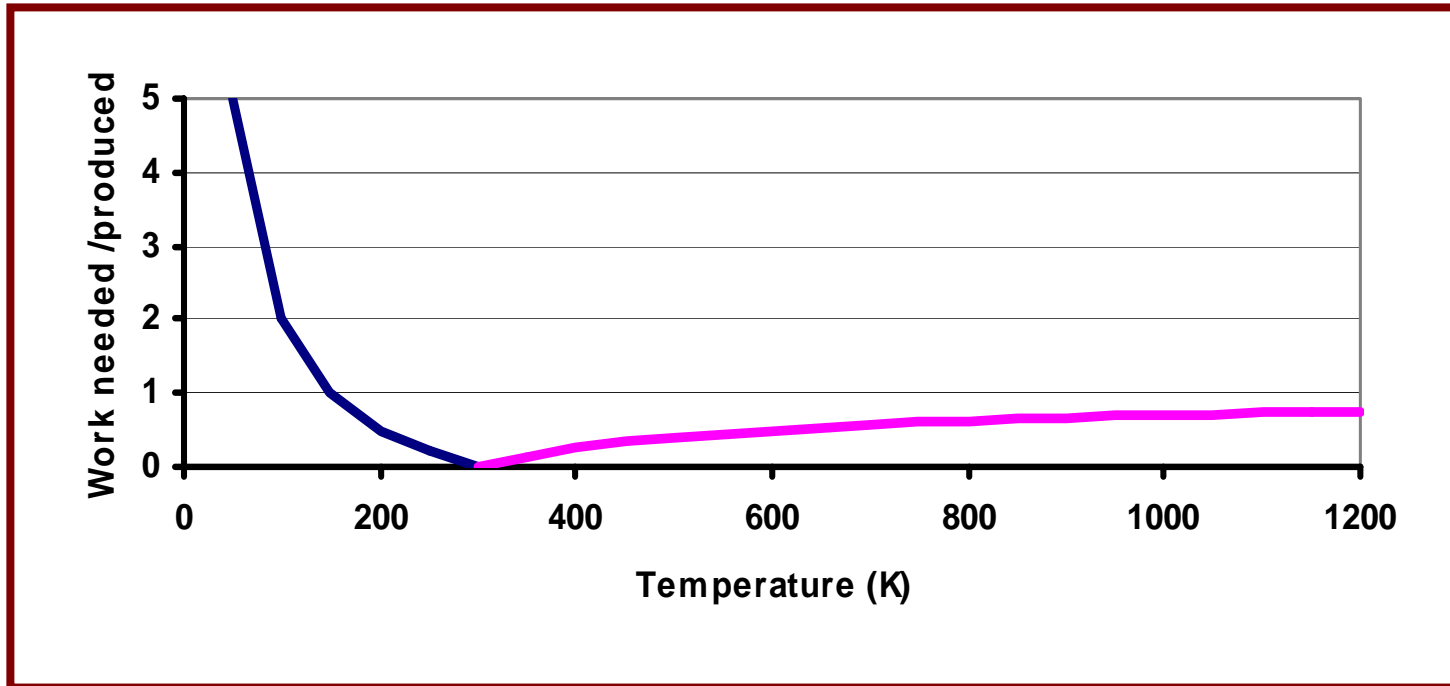



SOME INTERESTING DEDUCTIONS

❖ Firstly, there isn't a meaningful temperature of the source from which we can get the full conversion of heat to work. Only at ∞ temp. one can dream of getting the full 1 kW work output.



- ❖ Secondly, more interestingly, there isn't enough work available to produce 0 K. In other words, 0 K is unattainable. This is precisely the III LAW.
- ❖ Because, we don't know what 0 K looks like, we haven't got a starting point for the temperature scale!! That is why all temperature scales are at best empirical.



Summation of 3 Laws



You can't get something for nothing

To get work output you must give some thermal energy

You can't get something for very little

To get some work output there is a minimum amount of thermal energy that needs to be given

You can't get every thing

However much work you are willing to give 0 K can't be reached.

Violation of all 3 laws: try to get everything for nothing



Equivalence of Kelvin-Planck and Clausius statements

II Law basically a negative statement (*like most laws in society*). The two statements look distinct. We shall prove that violation of one makes the other statement violation too.

Let us suspect the Clausius statement-it *may be* possible to transfer heat from a body at colder to a body at hotter temperature without supply of work



Combine the two. The reservoir at T_2 has not undergone any change (Q_2 was taken out and by pseudo-Clausius device and put back by the engine). Reservoir 1 has given out a net $Q_1 - Q_2$. We got work output of W . $Q_1 - Q_2$ is converted to W with no net heat rejection. This is violation of Kelvin-Planck statement.

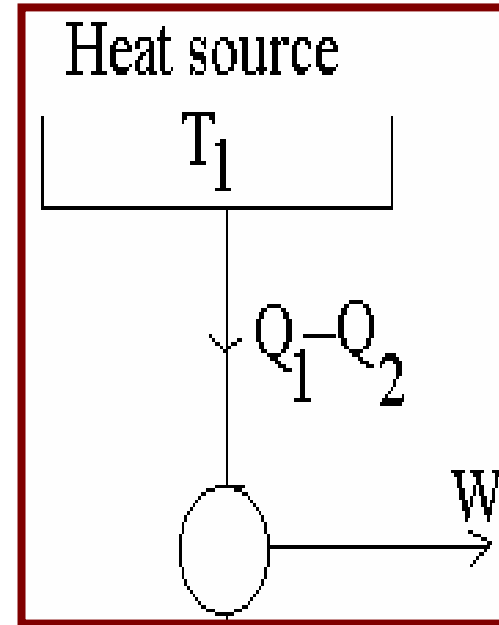
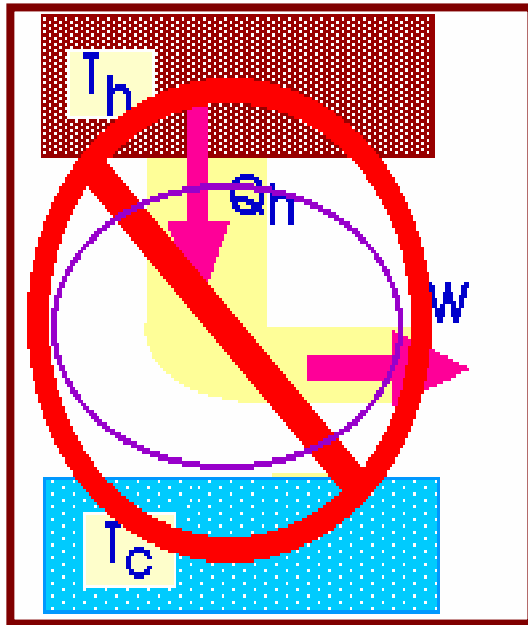

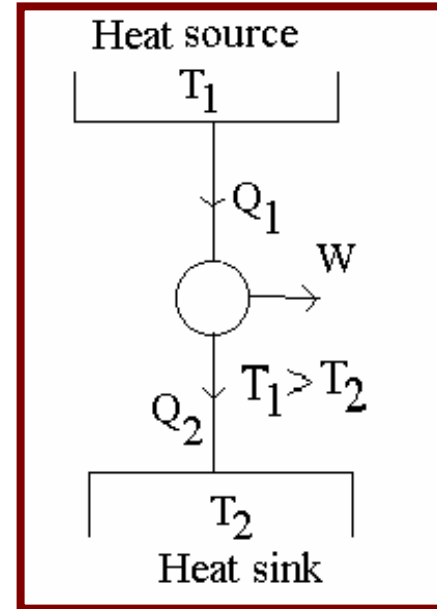
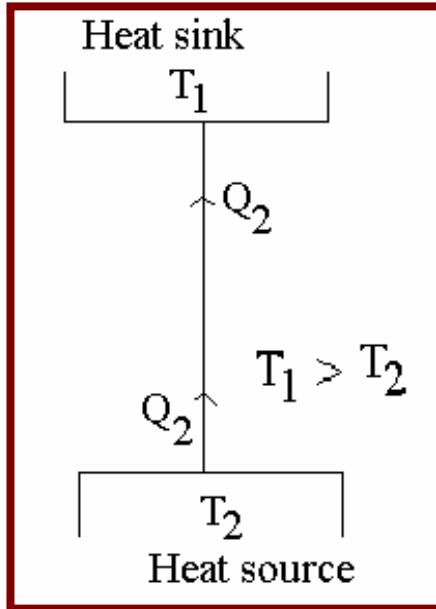

Let us have a heat engine operating between T_1 as source and T_2 as a sink. Let this heat engine reject exactly the same Q_2 (as the pseudo-Clausius device) to the reservoir at T_2 . To do this an amount of Q_1 needs to be drawn from the reservoir at T_1 . There will also be a $W = Q_1 - Q_2$



Moral: If an engine/refrigerator violates one version of II Law,
it violates the other one too.

All reversible engine operating between the same two fixed temperatures will have the same η and COPs.

If there exists a reversible engine/ or a refrigerator which can do better than that, it will violate the Clausius statement.



Let us assume that Clausius statement is true and *suspect* Kelvin-Planck statement

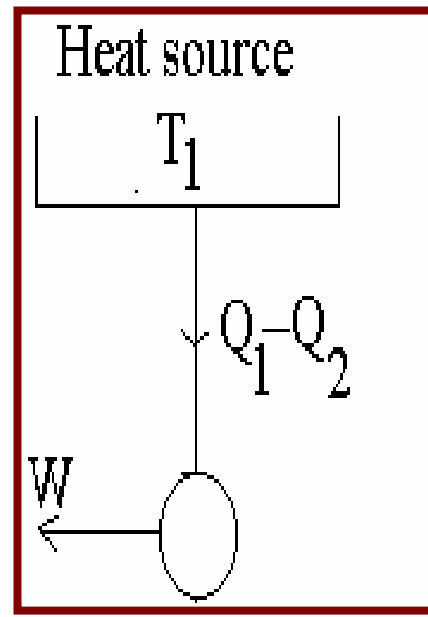
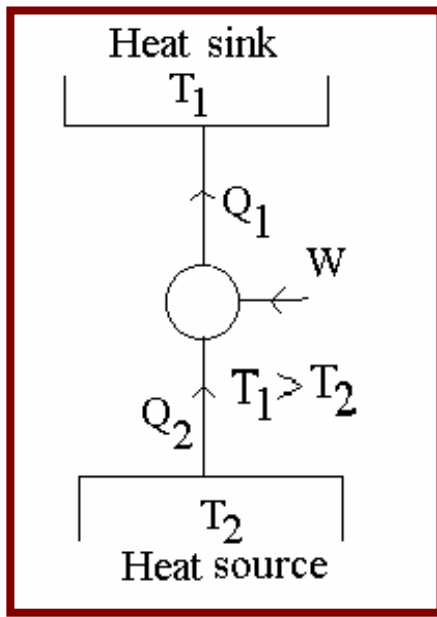



- Pseudo Kelvin Planck engine requires only Q_1 - Q_2 as the heat interaction to give out W (because it does not reject any heat) which drives the Clausius heat pump.



❖ **Combining the two yields:**

- The reservoir at T_1 receives Q_1 but gives out $Q_1 - Q_2$ implying a net delivery of Q_2 to it.
- Q_2 has been transferred from T_2 to T_1 without the supply of any work!!
- *A violation of Clausius statement.*

May be possible?

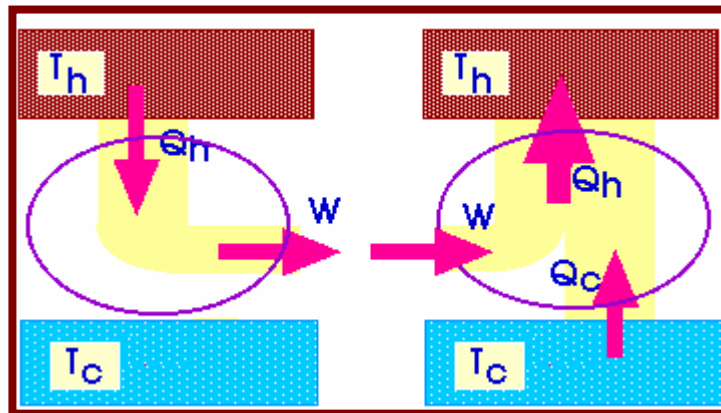

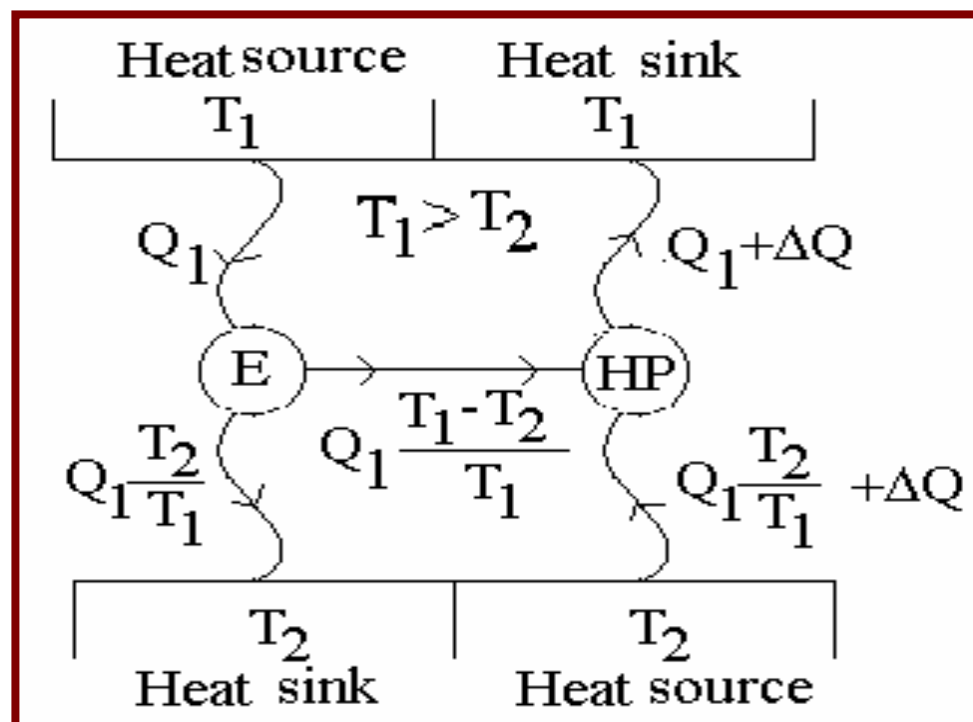



- Let us presume that the HP is super efficient!!
- For the same work given out by the engine E, it can pick up an extra DQ from the low temperature source and deliver over to reservoir at T1. The net effect is this extra DQ has been transferred from T2 to T1 with no external work expenditure. Clearly, a violation of Clausius statement!!



❖ **Sum up**

- ❖ Heat supplied = q_1 ; source temperature = t_1 ; sink temperature = t_2
- ❖ Maximum possible efficiency = $W/Q_1 = (T_1 - T_2)/T_1$
- ❖ Work done = $W = Q_1(T_1 - T_2)/T_1$

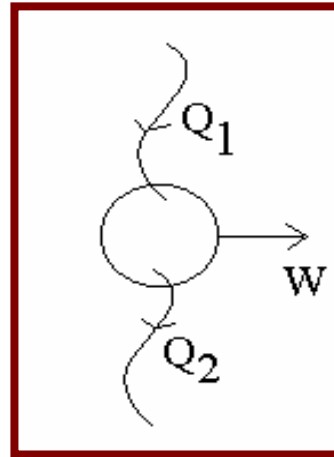

Applying I Law

Sum of heat interactions = sum of work interactions

$$Q_1 + Q_2 = W = Q_1 (T_1 - T_2) / T_1$$

Q_1 is +ve heat interaction; Q_2 is -ve heat interaction



- ❖ Heat rejected = -ve heat interaction = $-Q_2 = (Q_1 - W) = Q_1 T_2 / T_1$
- ❖ For a reversible heat engine operating in a cycle $Q_1 / T_1 + Q_2 / T_2 = 0$
- ❖ or $S(Q/T) = 0$

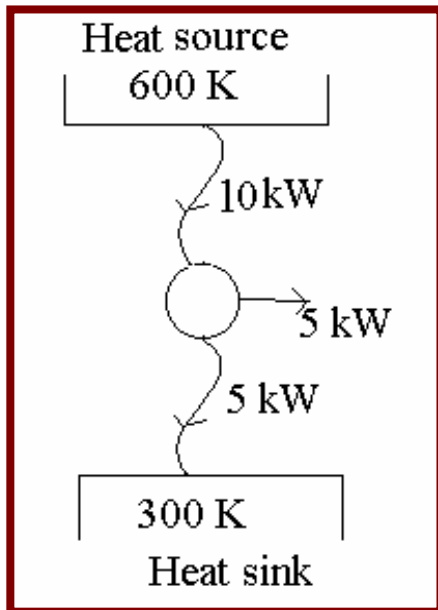

Ideal engine

$$10,000/600 + (-5000/300) = 0$$

Not so efficient engine

$$10,000/600 + (-7000/300) < 0$$

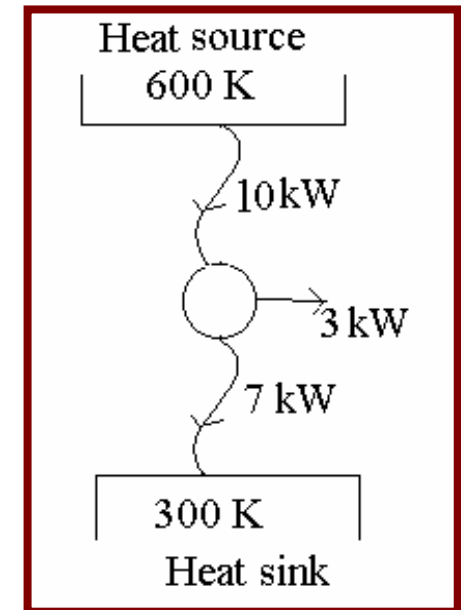



Module 7

Entropy



Clasiu's Inequality

Suppose we have an engine that receives from several heat reservoirs and rejects heat to several reservoirs, we still have the equation valid.

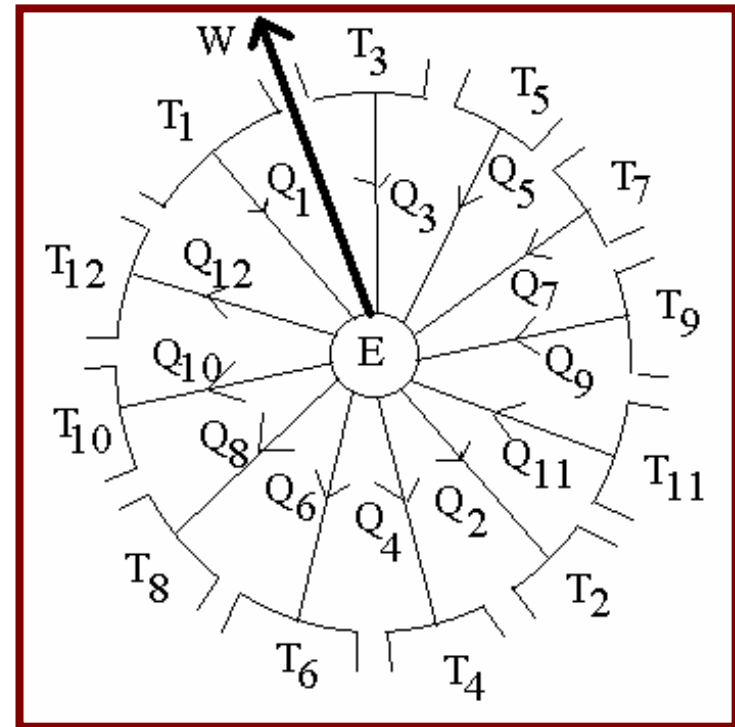



Clasiu's Inequality

(contd...)

- ❖ **With reference to previous fig,**
- Assume that reservoir at T_1 gets its Q_1 with the help of a fictitious heat pump operating between a source T_0 and T_1 .
The same for 3,5,7....
- Similarly, assume that reservoir at T_2 rejects the heat Q_2 through a fictitious heat engine to the sink at T_0 . The same for 4,6,8....



Clasiu's Inequality (contd...)

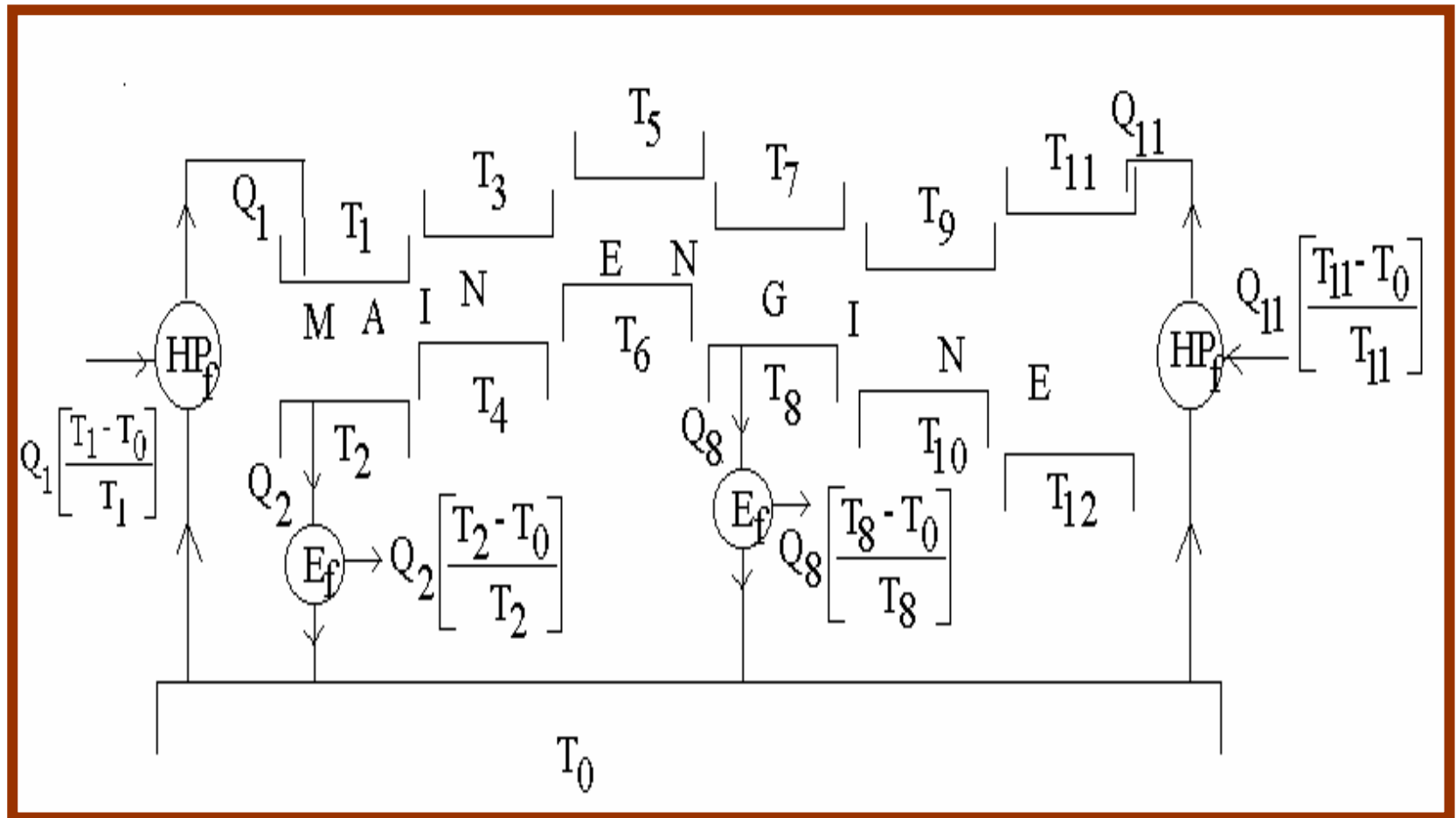



Clasiu's Inequality

(contd...)

➤ **Sum of work inputs for** = $-Q_1 - Q_3 \dots \dots + Q_1 T_0 / T_1 + Q_3 T_0 / T_3 \dots \dots$

All fictitious heat pumps

➤ **Sum of work outputs of** = $Q_2 + Q_4 \dots \dots - Q_2 T_0 / T_2 - Q_4 T_0 / T_4 \dots \dots$

All fictitious heat engines

❖ *[Note that the sign convention for work is already taken into account]*



Clasiu's Inequality

(contd...)

- ❖ The net of work inputs + work outputs of all the fictitious units

$$= -Q_1 - Q_3 \dots + Q_2 + Q_4 \dots + T_o [Q_1 / T_1 + Q_3 / T_3 \dots - Q_2 / T_2 - Q_4 / T_4 \dots]$$

But we know that for the main engine at the centre

- ❖ $W = Q_1 + Q_3 \dots - Q_2 - Q_4 \dots$ [after taking the sign into account]



Clasiu's Inequality

(contd...)

- If we consider the entire system consisting of all the reservoirs 1-12 and the fictitious source at T_0 , the work output of our main engine must be compensated by the works of fictitious engines (Otherwise the overall system will be delivering work by interaction with a single source at T_0).



Clasiu's Inequality (contd...)



This is possible only when

➤ $T_o [Q_1 / T_1 + Q_3 / T_3 \dots - Q_2 / T_2 - Q_4 / T_4 \dots] = 0$

➤ which implies that $Q_1 / T_1 + Q_3 / T_3 \dots - Q_2 / T_2 - Q_4 / T_4 \dots = 0$

❖ **In general**, $S(Q/T) = 0$ provided the engine is perfectly reversible.

If it is not $S(Q/T) < 0$

Therefore in general $S(Q/T) \leq 0$

Since, summation can be replaced by an integral $(\delta Q / T) \leq 0$.



Clasiu's Inequality

(contd...)

- The cyclic integral is to remind us that II Law holds only for a cycle.
- Note: Equality holds when the cycle is reversible.
< sign will be the most probable one for real cycles.
- Just as we had $dW = p dV$
- ❖ Can we guess that there is something emerging to define Q?



Clasiu's Inequality

(contd...)



- ❖ Is there (something) which is $= dQ/T$? Or $dQ = T \cdot$ (something) ???
- ❖ In W, p, V relation on the right hand side p and V are properties.
- ❖ Is this (something) also a property?
- ❖ For an adiabatic process we said $dQ = 0$. Does that (something) remain invariant during an adiabatic process?



The Concept Of Entropy

- ❖ Consider a reversible cycle constructed as shown. Since we will be integrating $\int \delta Q / T$ over the entire process say 1-2 along A or B, processes A and B need not be isothermal.

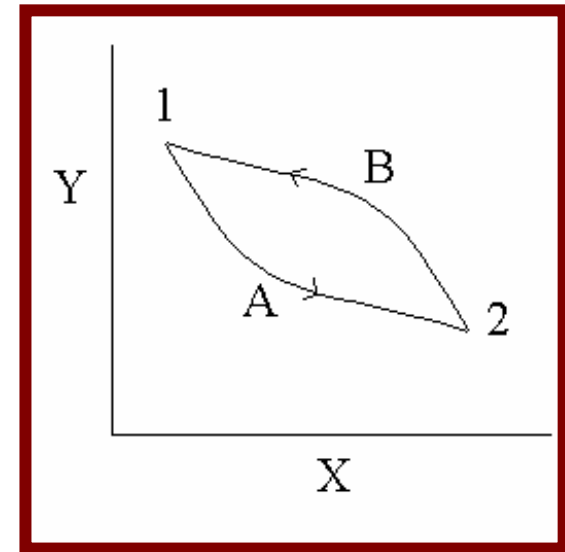



The Concept of Entropy

(contd...)

$$\diamond (\delta Q / T) = \int \delta Q / T \Big|_{\text{along } 1A2} + \int \delta Q / T \Big|_{\text{along } 2B1} = 0$$

\diamond If A and B are reversible and <0 if they are not.

$$\diamond \int \delta Q / T \Big|_{\text{along } 1A2} = - \int \delta Q / T \Big|_{\text{along } 2B1}$$

$$\diamond \int \delta Q / T \Big|_{\text{along } 1A2} = \int \delta Q / T \Big|_{\text{along } 1B2}$$



The Concept of Entropy

(contd...)

- ❖ In other words the integral remains the same no matter what the path is. It can be simply written as $S_2 - S_1$. The value depends only on the end states and not on the path followed. So it is a state function or a property.
- ❖ Like energy entropy (s) is also an extensive property. It will have the units of J/K. Similar to energy where we converted it into specific property, specific entropy (lower case s) will have units of J/kg K (same as specific heat)



The Concept of Entropy

(contd...)



$${}^1\int_2 \delta Q / T = S_2 - S_1 \quad \text{or} \quad {}^1\int_2 \delta q / T = s_2 - s_1 \quad | \quad \delta q / T = \delta s \quad \text{or} \quad \delta q = T \delta s$$

❖ Lesson learnt:

- Just as we can represent work interactions on P-V plane
- we can represent heat interactions on T-S plane.
- Naturally, T will be the ordinate and S will be the abscissa.
- All constant temperature lines will be horizontal and constant entropy lines vertical. So Carnot cycle will be just a rectangle.



The Concept of Entropy

(contd...)

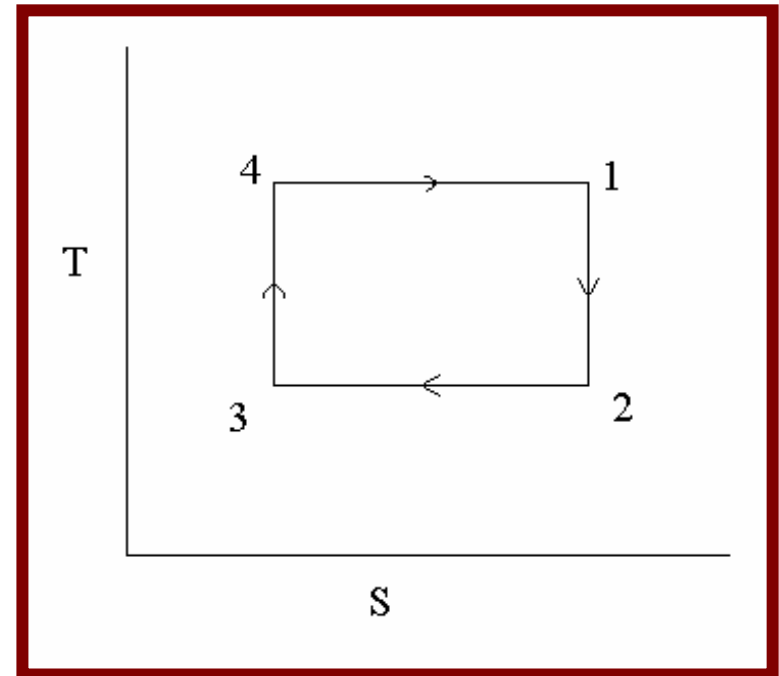
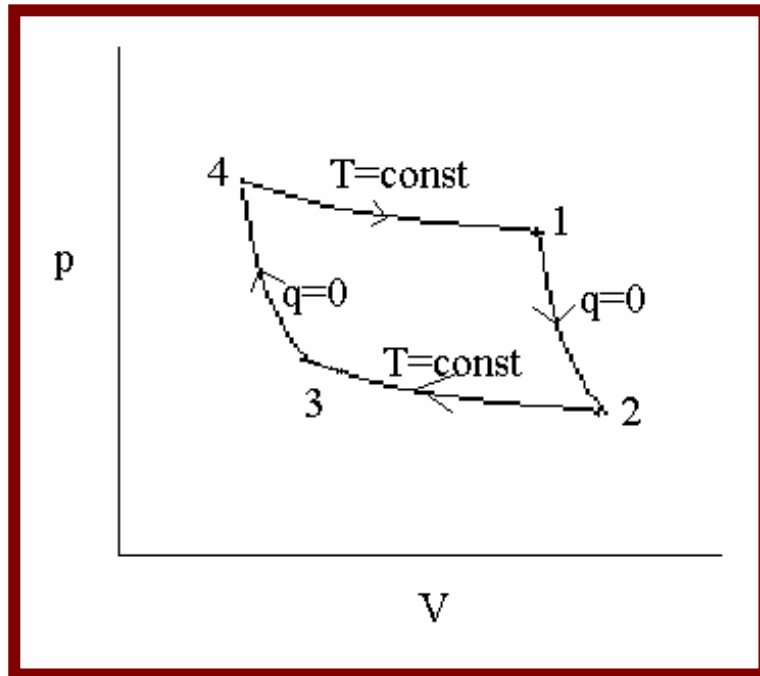

- ❖ Integrals under P-V plane give work interaction
- ❖ Integrals under T-S plane give heat interactions



Calculations

- Let us invoke the I law for a process namely $\delta q = \delta w + du$
- Substitute for $\delta q = Tds$ and $\delta w = p dv$ $Tds = pdv + du$
- For a constant volume process we have $Tds = du \dots (1)$
- We have by definition $h = u + pv$
- Differentiating $dh = du + pdv + vdp$
 $dh = Tds + vdp$
- For a constant pressure process $Tds = dh \dots (2)$



Calculations (contd...)

❖ **For a perfect gas** $du=c_v dT$ and $dh=c_p dT$

Substitute for du in (1) and dh in (2)

$$\text{for } v=\text{const} \quad Tds = c_v dT \quad \text{or} \quad dT/ds \Big|_{v=\text{const}} = T / c_v$$

$$\text{for } p=\text{const} \quad Tds = c_p dT \quad \text{or} \quad dT/ds \Big|_{p=\text{const}} = T / c_p$$

1. Since $c_p > c_v$ a constant pressure line on T-s plane will be flatter than a constant volume line.
2. The both (isobars and isochores) will have +ve slopes and curve upwards because the slope will be larger as the temperature increases

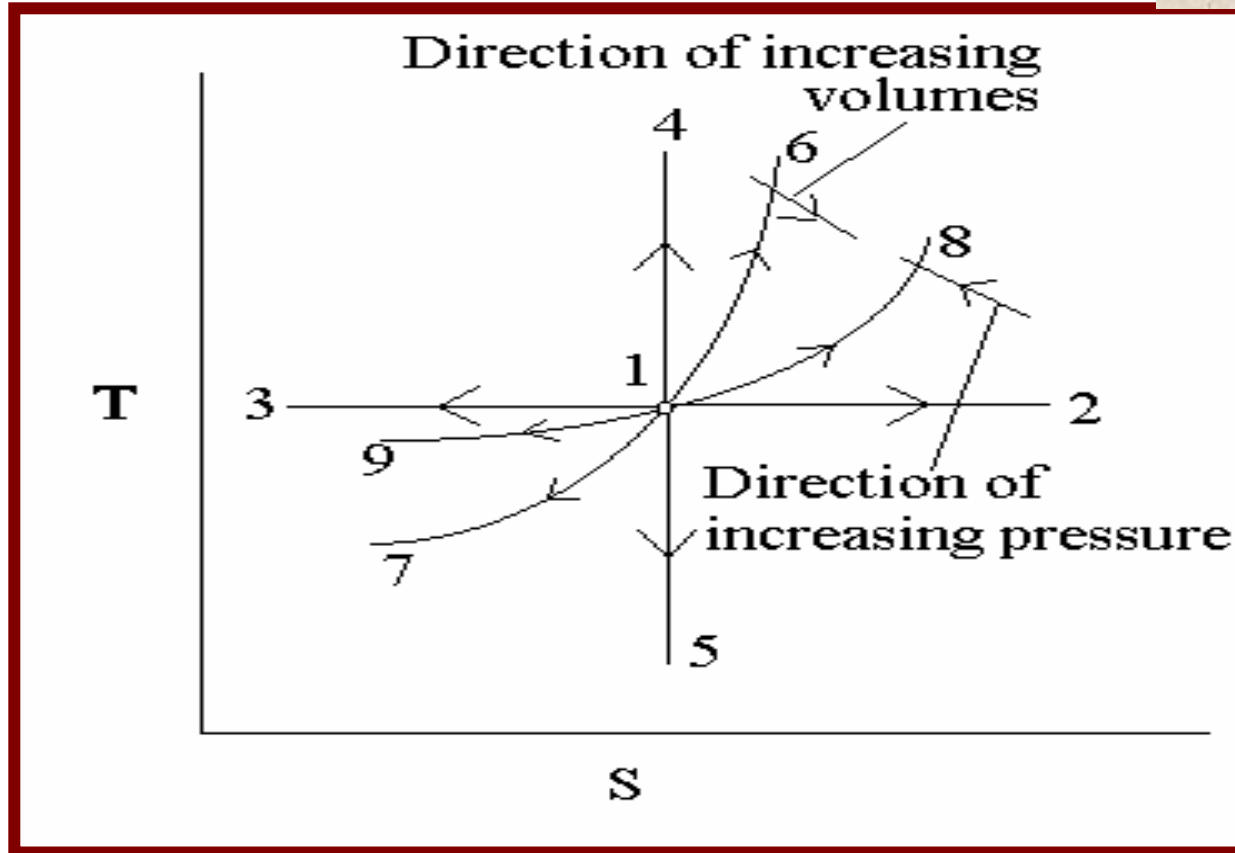

7--6 Const V line

9-1-8 Const. P line



	s	T	p	v
1-2 Isothermal expansion	↑	—	↓	↑
1-3 Isothermal compression	↓	—	↑	↓
1.4 Isentropic compression	—	↑	↑	↓
1-5 Isentropic expansion	—	↓	↓	↑
1-6 Isochoric heating	↑	↑	↑	—
1-7 Isochoric cooling	↓	↓	↓	—
1-8 Isobaric heating/expansion	↑	↑	—	↑
1-9 Isobaric cooling/compression	↓	↓	—	↓



Comparison Between P-v and T-s Planes

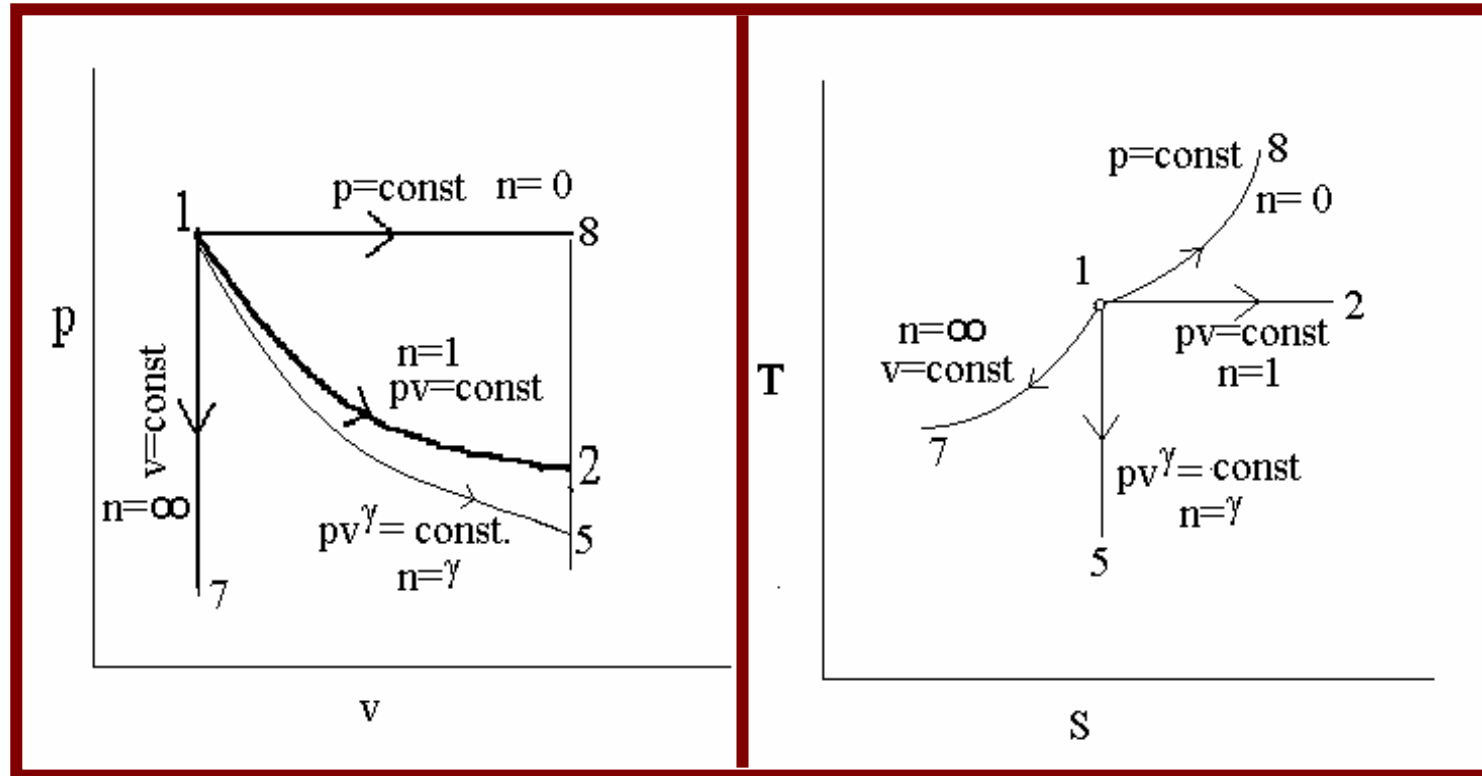



Comparison Between P-v and T-s Planes



(contd...)

- A similar comparison can be made for processes going in the other direction as well.
- Note that n refers to general index in $pv^n = \text{const.}$

Note:

- ❖ For $1 < n < \gamma$ the end point will lie between 2 and 5
- ❖ For $n > \gamma$ the end point will lie between 5 and 7



Comparison Between P-v and T-s Planes (contd...)

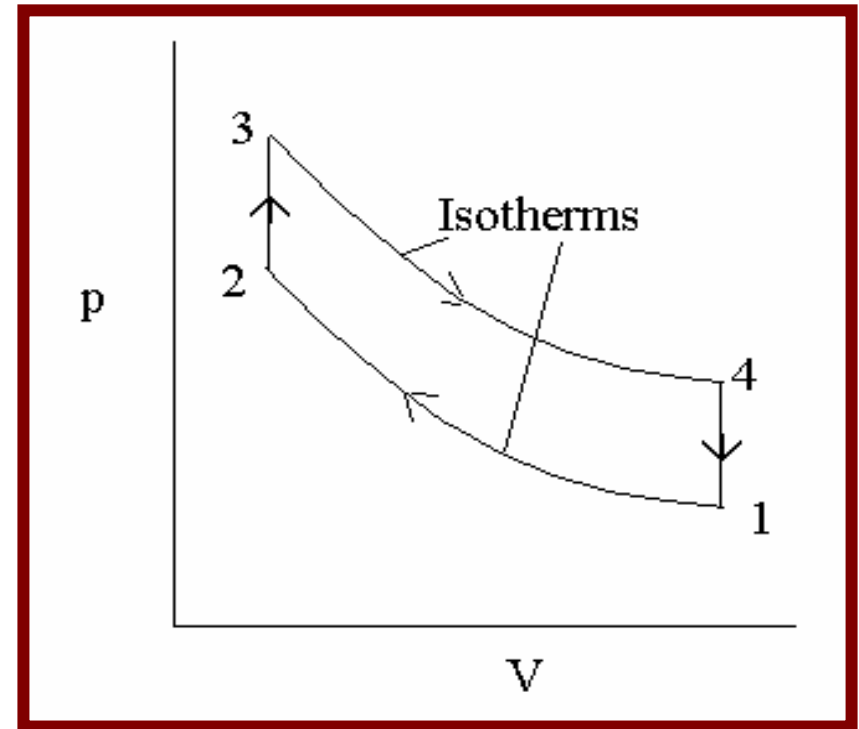
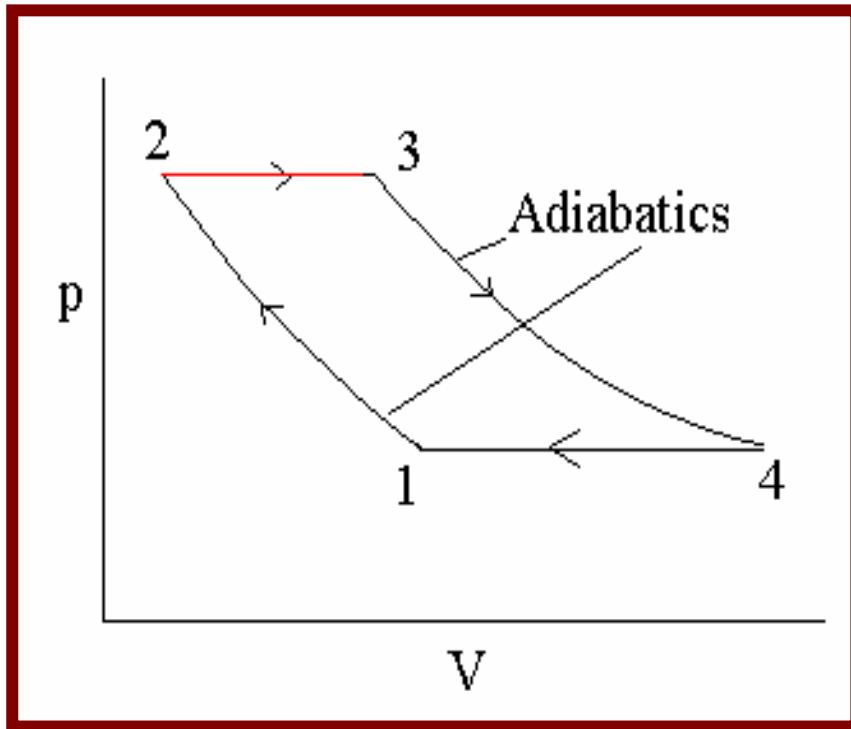



Comparison Between P-v and T-s Planes



(contd...)

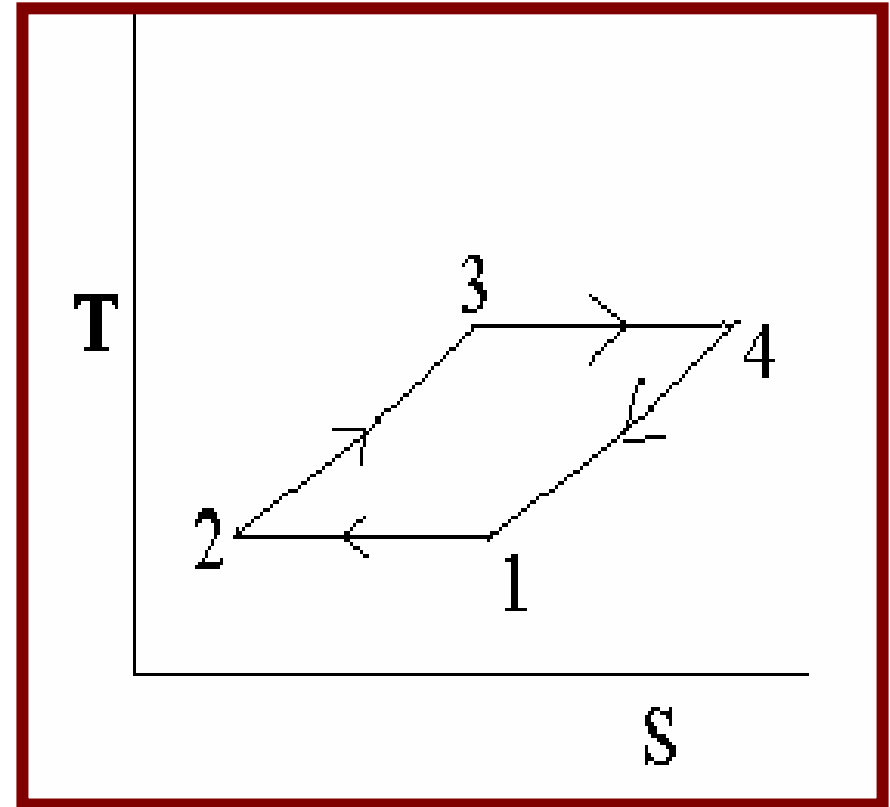
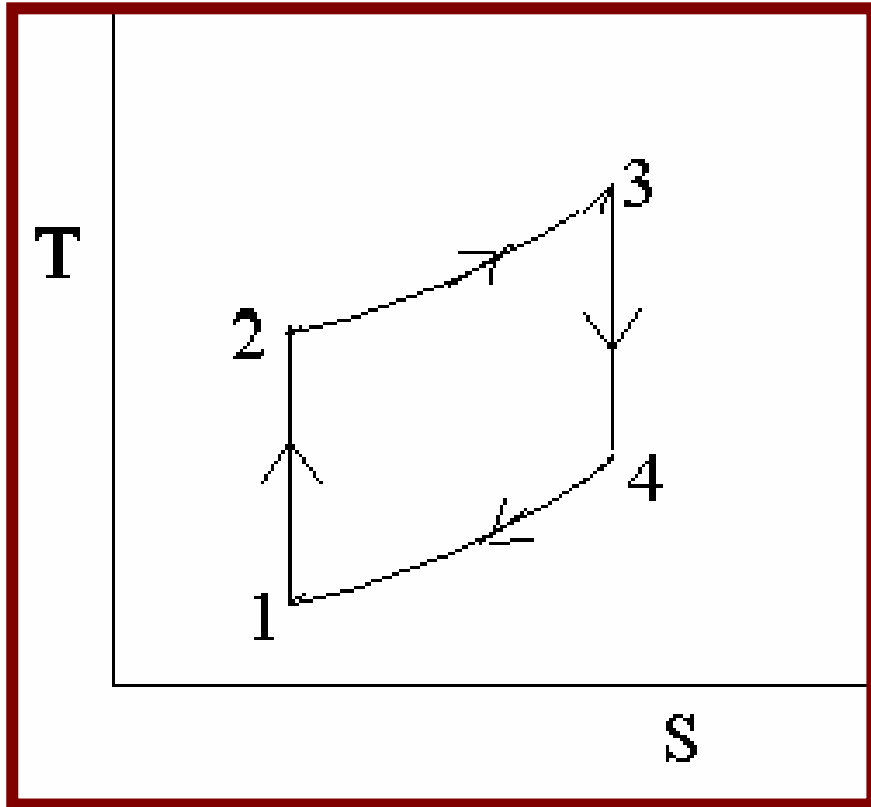

Note: All work producing cycles will have a clockwise direction even on the T-s plane



Comparison Between P-v And T-s Planes (Contd...)

Consider the Clausius inequality

$$\int \delta Q / T \leq 0$$

In the cycle shown let A be a reversible process (R) and B an irreversible one (ir), such that 1A2B1 is an irreversible cycle.

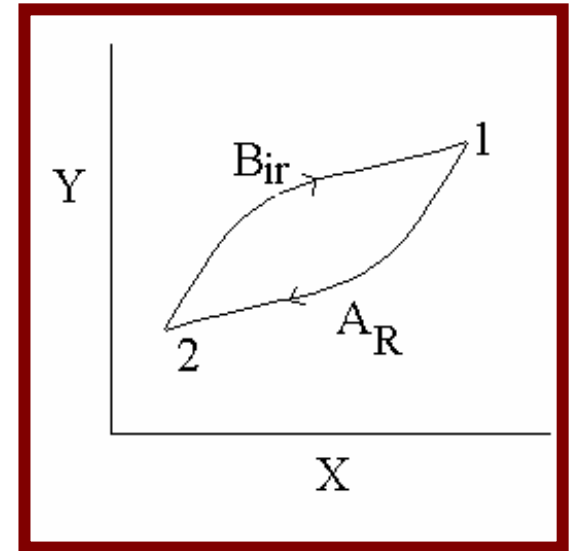



Comparison Between P-v And T-s Planes (Contd...)

❖ Applying Clausius inequality

$$\delta Q / T \Big|_{\text{along } 1A2} + \int \delta Q / T \Big|_{\text{along } 2B1} < 0$$

(because the cycle is irreversible < sign applies)

Since A is reversible $\int \delta Q / T \Big|_{\text{along } 1A2} = S_2 - S_1$

$$S_2 - S_1 + \int \delta Q / T \Big|_{\text{along } 2B1} < 0$$



Comparison Between P-v And T-s Planes

(Contd...)

- Implying that $\int \delta Q / T \mid \text{along } 2B1 < S_1 - S_2$
- Or $S_1 - S_2 > \int \delta Q / T \mid \text{along } 2B1$
- Had B also been reversible $\int \delta Q / T \mid \text{along } 2B1$ would have been equal to $S_1 - S_2$



Moral 1

$$(S_1 - S_2)_{\text{irreversible}} > (S_1 - S_2)_{\text{reversible}}$$

An irreversible process generates more entropy than a reversible process.

Moral 2:

If process B is adiabatic but irreversible $S_1 - S_2 > 0$ or $S_1 > S_2$

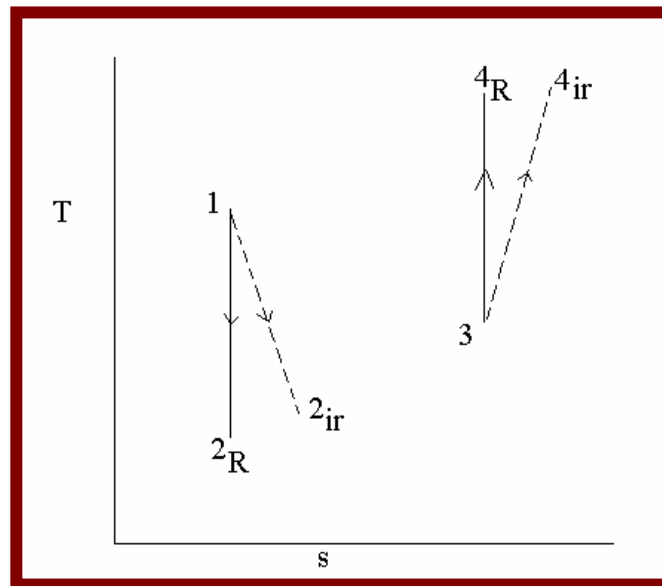



❖ In general we can say $ds \geq \delta Q / T$ or $\delta Q \leq T ds$

(equality holding good for reversible process)

1-2_R Isentropic expansion (reversible)

1-2_{ir} Non-isentropic expansion (irreversible)

3-4_R Isentropic compression (reversible)

3-4_{ir} Non-isentropic compression (irreversible)



An irreversible engine can't produce more work than a reversible one.

❖ *An irreversible heat pump will always need more work than a reversible heat pump.*

• An irreversible expansion will produce less work than a reversible expansion

❖ *An irreversible compression will need more work than a reversible compression*



Calculation of change in entropy during various reversible processes for perfect gases



Starting point of equation

$$\delta q - \delta w = du$$

Rewritten as

$$Tds = pdv + c_v dT$$

1. Constant volume process $dv=0$

$$ds = c_v dT/T$$

which on integration yields

$$s_2 - s_1 = c_v \ln(T_2/T_1)$$

2. For constant pressure process

$$ds = c_p dT/T$$

which on integration yields

$$s_2 - s_1 = c_p \ln(T_2/T_1)$$

3. Constant temperature process ($dT=0$)

$$Tds = pdv$$

But $p = RT/v$

$$ds = R dv/v$$

Which on integration yields $s_2 - s_1 = R \ln(v_2/v_1) = R \ln(p_1/p_2)$



Calculation Of Change In Entropy During Various Reversible Processes For Perfect Gases



Starting point of equation

$$\delta q - \delta w = du$$

Rewritten as

$$Tds = pdv + cvdT$$

1. Constant volume process $dv=0$

$$ds = c_v dT/T$$

which on integration yields

$$s_2 - s_1 = c_v \ln(T_2/T_1)$$

2. For constant pressure process

$$ds = c_p dT/T$$

which on integration yields

$$s_2 - s_1 = c_p \ln(T_2/T_1)$$



4. General equation $ds = p \, dv/T + c_v \, dT/T = R \, dv/v + c_v \, dT/T$

Which on integration yields $s_2 - s_1 = R \ln(v_2/v_1) + c_v \ln(T_2/T_1)$

Using $T \, ds = c_p \, dT - v \, dp$ (see slide 130) $s_2 - s_1 = c_p \ln(T_2/T_1) - R \ln(p_2/p_1)$

5. Throttling $dT=0$ $p=RT/v$ from which $s_2 - s_1 = R \ln(p_1/p_2)$

Since $p_2 < p_1$, throttling is always irreversible

What the thermal engineer should be able to do

1. *Identify any process or series of processes including components of cyclic processes*
2. *Select control masses or volumes as appropriate*
3. *Identify interactions between subsystems*
4. *Sketch a diagram showing control surfaces and interactions and a process diagram showing state changes*
5. *Obtain all necessary properties at each state given independent properties - u , v , h , s , T , P , composition*
6. *Calculate interactions directly where possible*
7. *Apply the 1st Law to any process or set of processes*
8. *Calculate the behavior of an isentropic process or a non-isentropic process given the isentropic efficiency (s_1 and s_2 related)*
9. *Put it all together and solve the system of algebraic equations*
10. *Estimate the system performance*

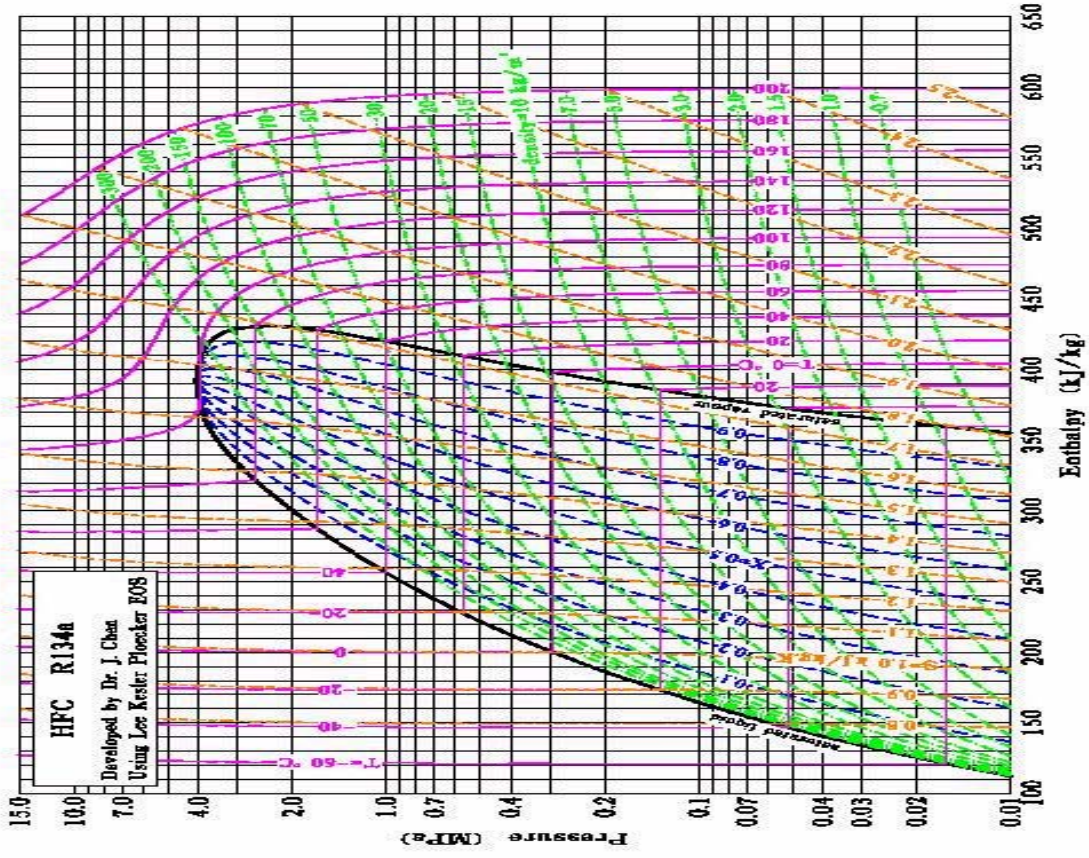

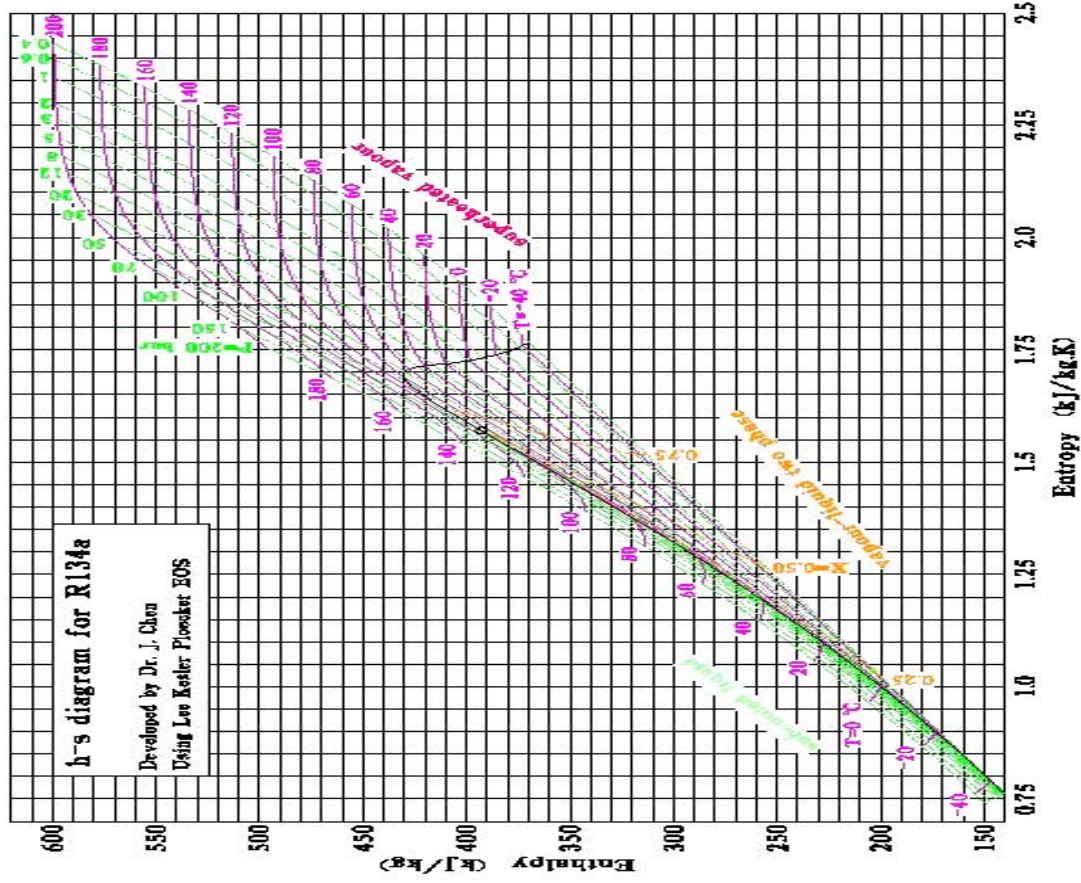

References and resources:

Books Authored by

- ➡ Van Wylen
- ➡ Spalding and Cole
- ➡ Moran and Shapiro
- ➡ Holman
- ➡ Rogers and Mayhew
- ➡ Wark

Useful web sites (<http://...>)

- ➡ turbu.engr.ucf.edu/~aim/egn3343
- ➡ webbook.nist.gov/chemistry/fluid/
(gives the current world standards of properties for various fluids)
- ➡ www.uic.edu/~mansoori/Thermodynamic.Data.and.Property.html (gives links to all web based learning in thermodynamics)
- ➡ fbox.vt.edu:10021/eng/mech/scott

Problems with solutions:

1. A 1-m³ tank is filled with a gas at room temperature 20°C and pressure 100 Kpa. How much mass is there if the gas is

- a) Air
- b) Neon, or
- c) Propane?

Solution:

Given: T=273K; P=100KPa; M_{air}=29; M_{neon}=20; M_{propane}=44;

$$m = \frac{P * V * M}{R * T}$$

$$m_{air} = \frac{10^5 * 1 * 29}{8314 * 293} = 1.19 \text{ Kg}$$

$$m_{neon} = \frac{20}{29} * 1.19 = 0.82 \text{ Kg}$$

$$m_{propane} = \frac{44}{20} * 0.82 = 1.80 \text{ Kg}$$

2. A cylinder has a thick piston initially held by a pin as shown in fig below. The cylinder contains carbon dioxide at 200 Kpa and ambient temperature of 290 k. the metal piston has a density of 8000 Kg/m³ and the atmospheric pressure is 101 Kpa. The pin is now removed, allowing the piston to move and after a while the gas returns to ambient temperature. Is the piston against the stops?

Schematic:

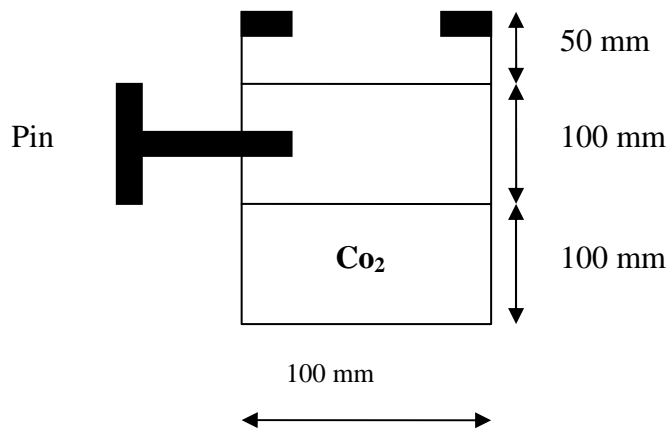

Solution:

Given: P=200kpa;

$$V_{\text{gas}} = \frac{\pi}{4} * 0.1^2 * 0.1 = 0.7858 * 10^{-3} \text{ m}^3 : T=290 \text{ k} : V_{\text{piston}}=0.785 * 10^{-3} :$$

$$m_{\text{piston}} = 0.785 * 10^{-3} * 8000 = 6.28 \text{ kg}$$

$$\text{Pressure exerted by piston} = \frac{6.28 * 9.8}{\frac{\pi}{4} * 0.1^2} = 7848 \text{ kpa}$$

When the metal pin is removed and gas T=290 k

$$v_2 = \frac{\pi}{4} * 0.1^2 * 0.15 = 1.18 * 10^{-3} \text{ m}^3$$

$$v_1 = 0.785 * 10^{-3} \text{ m}^3$$

$$p_2 = \frac{200 * 0.785}{1.18} = 133 \text{kpa}$$

Total pressure due to piston + weight of piston = 101 + 7.848 kpa

$$= 108.848 \text{ pa}$$

Conclusion: Pressure is greater than this value. Therefore the piston is resting against the stops.

3. A cylindrical gas tank 1 m long, inside diameter of 20cm, is evacuated and then filled with carbon dioxide gas at 25⁰c. To what pressure should it be charged if there should be 1.2 kg of carbon dioxide?

Solution:

T= 298 k: m=1.2kg:

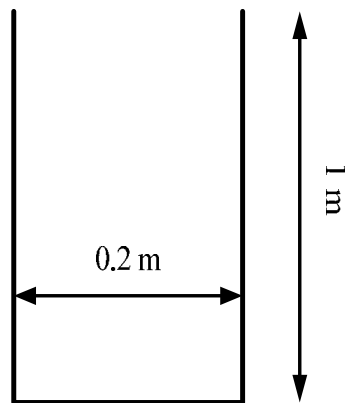

$$p = 1.2 * \frac{8314}{44} * \frac{298}{\frac{\pi}{4} * 0.2^2 * 1} = 2.15 \text{ Mpa}$$

4. A 1-m³ rigid tank with air 1 Mpa, 400 K is connected to an air line as shown in fig: the valve is opened and air flows into the tank until the pressure reaches 5 Mpa, at which point the valve is closed and the temperature is inside is 450 K.

a. What is the mass of air in the tank before and after the process?

b. The tank is eventually cools to room temperature, 300 K. what is the pressure inside the tank then?

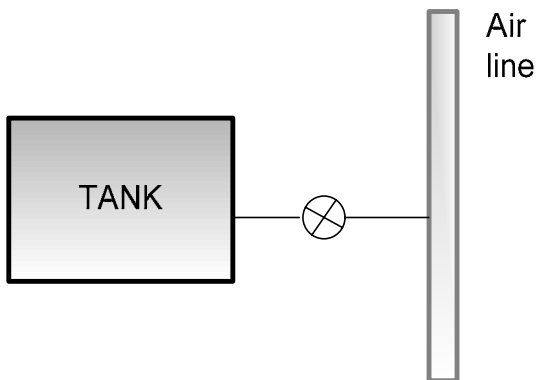

Solution:

$$P=10^6 \text{ Pa: } P_2=5*10^6 \text{ Pa: } T_1=400\text{K: } T_2=450 \text{ k}$$

$$m_1 = \frac{10^6 * 1 * 29}{8314 * 400} = 8.72\text{Kg}$$

$$m_2 = \frac{5 * 10^6 * 29}{8314 * 450} = 38.8\text{Kg}$$

$$P = 38.8 * \frac{8314}{29} * \frac{300}{1} = 3.34\text{Mpa}$$

5. A hollow metal sphere of 150-mm inside diameter is weighed on a precision beam balance when evacuated and again after being filled to 875 Kpa with an unknown gas. The difference in mass is 0.0025 Kg, and the temperature is 25⁰c. What is the gas, assuming it is a pure substance?

Solution:

$$m=0.0025\text{Kg: } P=875*10^3 \text{ Kpa: } T= 298 \text{ K}$$

$$M = \frac{8314 * 0.0025 * 298}{875 * 10^3 * \frac{\pi}{6} * 0.15^3} = 4$$

The gas will be helium.

6. Two tanks are connected as shown in fig, both containing water. Tank A is at 200 Kpa, $v=1\text{m}^3$ and tank B contains 3.5 Kg at 0.5 Mp, 400°C . The valve is now opened and the two come to a uniform state. Find the specific volume.

Schematic:

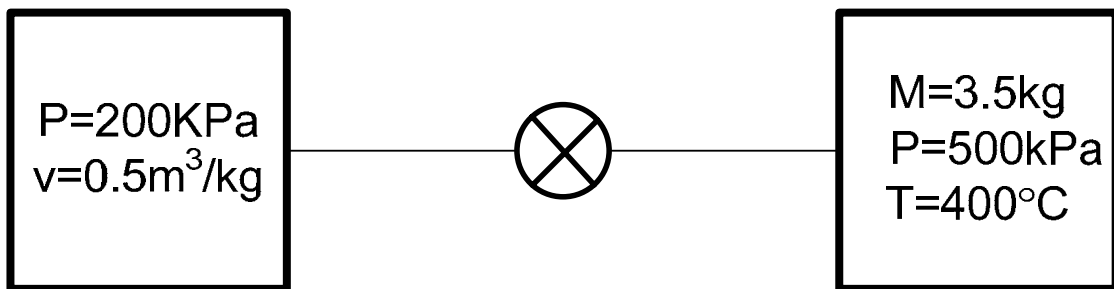

Known:

$$V=1\text{m}^3$$

$$M=2\text{ Kg}$$

$$v_f=0.001061\text{m}^3/\text{Kg}$$

$$v_g=0.88573\text{ m}^3/\text{Kg}$$

$$T=400^\circ\text{C}$$

$$m=3.5\text{ Kg}$$

Therefore it is a mixture of steam and water.

$$\text{Final volume}=2.16+1 =3.16\text{ m}^3$$

$$\text{Final mass}=2+3.5= 5.5\text{ Kg}$$

$$\text{Final specific volume}= 3.16/5.5=0.5745\text{ m}^3/\text{Kg}$$

$$m_{inA} = \frac{1}{0.5745} = 1.74\text{kg}$$

$$m_{inB} = \frac{2.16}{0.5745} = 3.76\text{Kg}$$

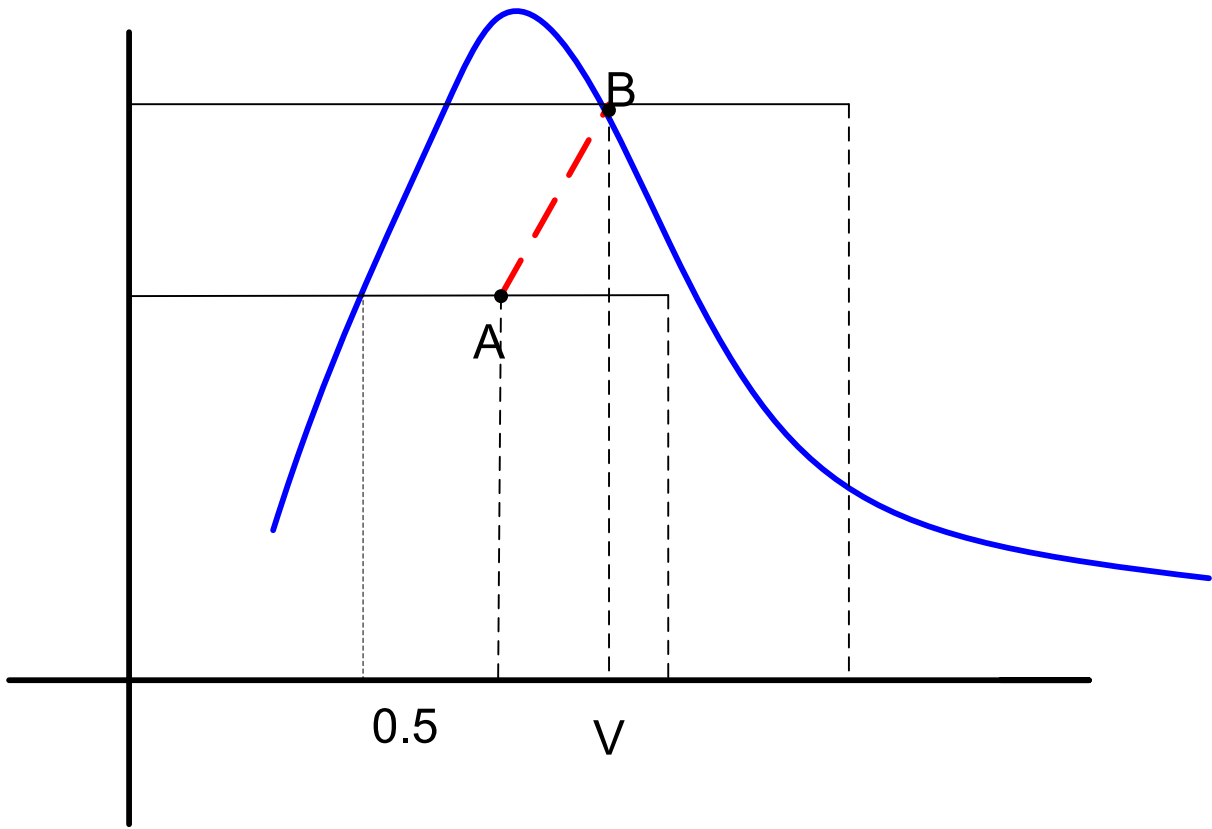

7.. The valve is now opened and saturated vapor flows from A to B until the pressure in B Consider two tanks, A and B, connected by a valve as shown in fig. Each has a volume of 200 L and tank A has R-12 at 25°C, 10 % liquid and 90% vapor by volume, while tank B is evacuated has reached that in A, at which point the valve is closed. This process occurs slowly such that all temperatures stay at 25 °C throughout the process. How much has the quality changed in tank A during the process?

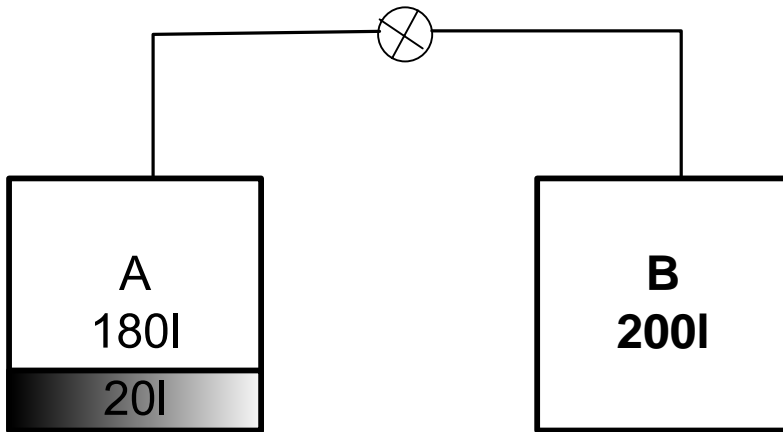

Solution: Given R-12

$$P = 651.6 \text{ KPa}$$

$$v_g = 0.02685 \text{ m}^3/\text{Kg}$$

$$v_f = 0.763 \times 10^{-3} \text{ m}^3/\text{Kg}$$

$$m = \frac{0.18}{0.02685} + \frac{0.02}{0.763 \times 10^{-3}}$$

$$= 6.704 + 26.212 = 32.916$$

$$x_1 = \frac{6.704}{32.916} = 0.2037$$

$$\text{Amount of vapor needed to fill tank B} = \frac{0.2}{0.02685} = 7.448 \text{ Kg}$$

Reduction in mass liquid in tank A = increase in mass of vapor in B

$$m_f = 26.212 - 7.448 = 18.76 \text{ Kg}$$

$$\text{This reduction of mass makes liquid to occupy} = 0.763 \times 10^{-3} * 18.76 \text{ m}^3 = 0.0143 \text{ m}^3$$

$$\text{Volume of vapor} = 0.2 - 0.0143 = 0.1857 \text{ L}$$

$$Mg = \frac{0.1857}{0.02685} = 6.916 \text{ Kg}$$

$$x_2 = \frac{6.916}{6.916 + 18.76} = 0.2694$$

$$\Delta x. \uparrow = 6.6 \%$$

8. A linear spring, $F = K_s (x - x_0)$, with spring constant $K_s = 500 \text{ N/m}$, is stretched until it is 100 mm long. Find the required force and work input.

Solution:

$$F = K_s (x - x_0) \quad x - x_0 = 0.1 \text{ m}$$

$$K_s = 500 \text{ N/m}$$

$$F = 50 \text{ N}$$

$$W = \frac{1}{2} \mathbf{FS} = \frac{1}{2} * \mathbf{50} * \mathbf{0.1} = \mathbf{2.53}$$

9. A piston / cylinder arrangement shown in fig. Initially contains air at 150 kpa, 400°C. The setup is allowed to cool at ambient temperature of 20°C.

- a. Is the piston resting on the stops in the final state? What is the final pressure in the cylinder?
- b. That is the specific work done by the air during the process?

Schematic:

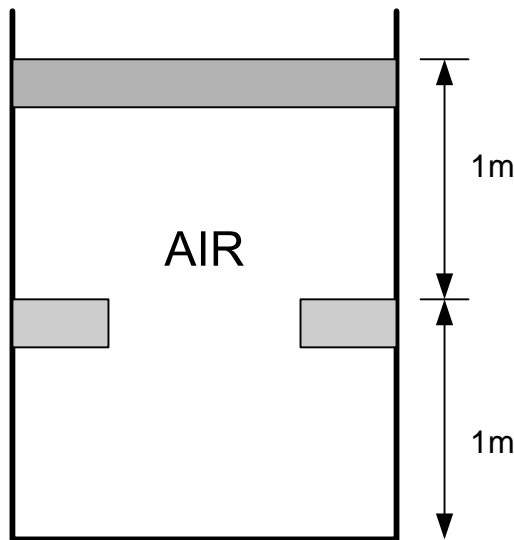

Solution:

$$p_1 = 150 \times 10^3 \text{ Pa}$$

$$T_1 = 673 \text{ K}$$

$$T_2 = 293 \text{ K}$$

$$\frac{P_1 * V_1}{T_1} = \frac{P_1 * V_2}{T_2}$$

$$1. \text{ If it is a constant pressure process, } V_2 = \frac{T_2}{T_1} * V_1 = \frac{293}{673} * A * 2 = 0.87m$$

Since it is less than weight of the stops, the piston rests on stops.

$$\frac{V_1}{T_1} = \frac{V_2}{T_2}$$

$$T_2 = \frac{V_2}{V_1} * T_1$$

$$= \frac{1 * 673}{2} = 336.5 \text{ K}$$

$$\frac{p_3}{T_3} = \frac{p_2}{T_2}$$

$$P_3 = \frac{P_2 * T_3}{T_2} = 150 * 10^3 * \frac{293}{336.5} = 130.6 \text{ KPa}$$

$$\text{Therefore } W = \frac{-150 * 10^3 * A * 1 * 8314 *}{150 * 10^3 * A * 2 * 29} = -96.5 \text{ KJ / Kg}$$

10. A cylinder, $A_{cyl} = 7.012\text{cm}^2$ has two pistons mounted, the upper one, $m_{p1}=100\text{kg}$, initially resting on the stops. The lower piston, $m_{p2}=0\text{kg}$, has 2 kg water below it, with a spring in vacuum connecting the two pistons. The spring force force is zero when the lower piston stands at the bottom, and when the lower piston hits the stops the volume is 0.3 m^3 . The water, initially at 50 kPa, $V=0.00206\text{ m}^3$, is then heated to saturated vapor.

- Find the initial temperature and the pressure that will lift the upper piston.
- Find the final T , P , v and work done by the water.

Schematic:

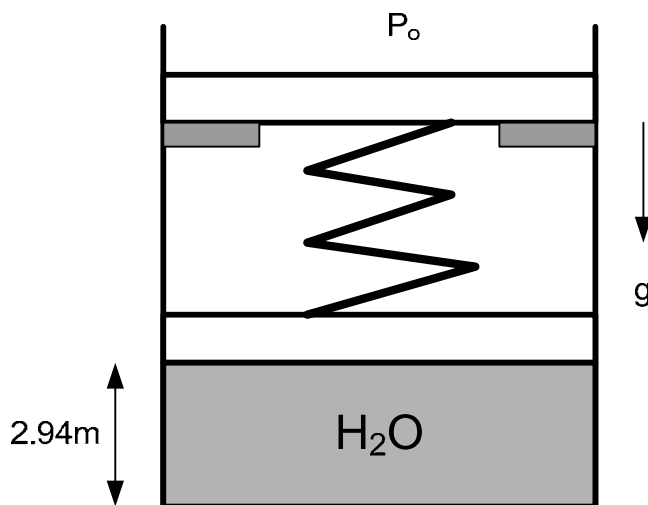

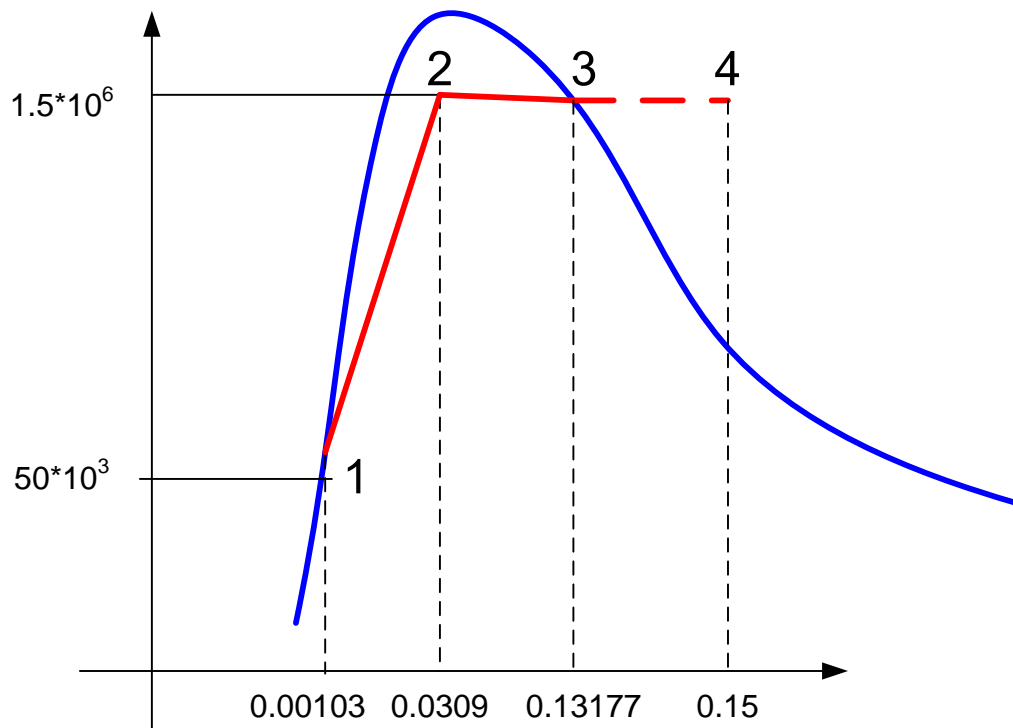

There are the following stages:

(1) Initially water pressure 50 kPa results in some compression of springs.

$$\text{Force} = 50 \cdot 10^3 \cdot 7.012 \cdot 10^{-4} = 35.06 \text{ N}$$

$$\text{Specific volume of water} = 0.00206/2 = 0.00103 \text{ m}^3/\text{kg}$$

$$\text{Height of water surface} = \frac{0.00206}{7.012 \cdot 10^{-4}} = 2.94 \text{ m}$$

$$\text{Spring stiffness} = \frac{35.06}{2.94} = 11.925 \text{ N/m}$$

(2) As heat is supplied, pressure of water increases and is balanced by spring reaction due to K8. This will occur till the spring reaction

$$= \text{Force due to piston} + \text{atm pressure}$$

$$=981+10^5 * 7.012*10^{-4} =1051 \text{ N}$$

$$\text{This will result when } S = \frac{1051}{11.925} = 88.134 \text{ m}$$

$$\text{At this average } V= 7.012* 10^{-4} * 88.134 =0.0618\text{m}^3$$

$$P = \frac{1051}{7.012 * 10^{-4}} = 1.5 \text{ Mpa}$$

(3) From then on it will be a constant pressure process till the lower piston hits the stopper. Process 2-3

$$\text{At this stage } V= 0.3 \text{ m}^3$$

$$\text{Specific volume} = 0.15 \text{ m}^3/\text{kg}$$

$$\text{But saturated vapor specific volume at } 1.5 \text{ Mpa} = 0.13177 \text{ m}^3/\text{kg}$$

$$V=0.26354 \text{ m}^3$$

(4) Therefore the steam gets superheated 3-4

$$\begin{aligned} \text{Work done} &= p_2(v_4 - v_2) + \frac{1}{2}(p_2 + p_1)(v_2 - v_1) \\ &= 1.5 * 10^6(0.15 - 0.0618) + \frac{1}{2}(1.5 * 10^6 + 50 * 10^3)(0.0618 - \\ &0.00103) \\ &= 178598.5 \text{ J} \\ &= 179 \text{ KJ} \end{aligned}$$

11. Two kilograms of water at 500 kPa, 20°C are heated in a constant pressure process (SSSF) to 1700°C. Find the best estimate for the heat transfer.

Solution:

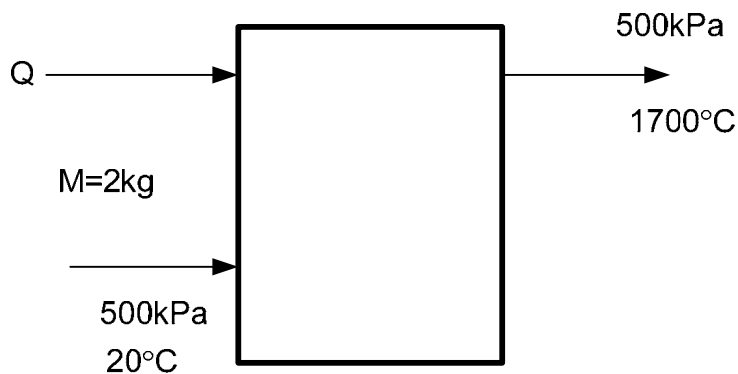

$$\begin{aligned}
 Q &= m [(h_2 - h_1)] \\
 &= 2[(6456 - 85)] \\
 &= 12743 \text{ KJ}
 \end{aligned}$$

Chart data does not cover the range. Approximately $h_2 = 6456 \text{ KJ/kg}$; $h_1 = 85 \text{ KJ}$;

$$\begin{aligned}
 500 \text{ kPa } 130^\circ\text{C} \quad h &= 5408.57 \\
 700^\circ\text{C} \quad h &= 3925.97
 \end{aligned}$$

$$\Delta h = 1482.6 \text{ kJ/kg}$$

$$262 \text{ kJ/kg} / 100^\circ\text{C}$$

12. Nitrogen gas flows into a convergent nozzle at 200 kPa, 400 K and very low velocity. It flows out of the nozzle at 100 kPa, 330 K. If the nozzle is insulated, find the exit velocity.

Solution:

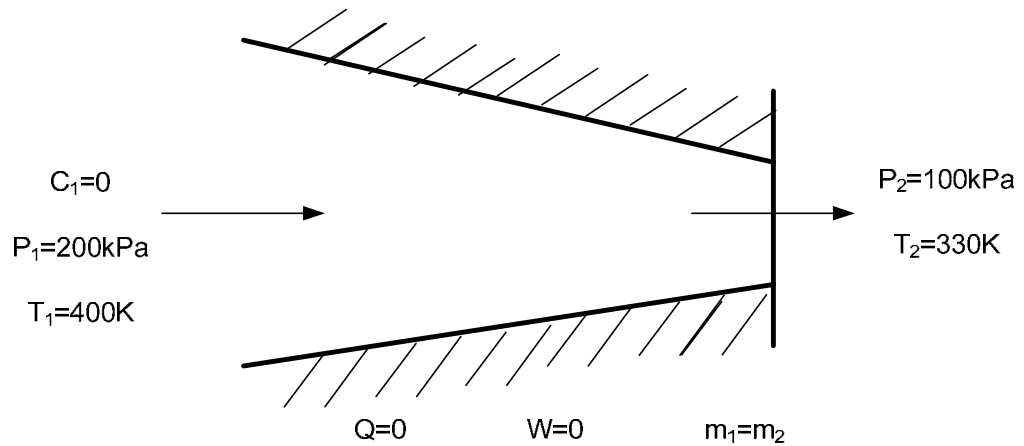

$$h_1 + \frac{c_1^2}{2} = h_2 + \frac{c_2^2}{2}$$

$$\frac{c_2^2}{2} = h_1 - h_2 = 415.31 \cdot 1000 - 342.4 \cdot 1000$$

$$c_2 = \sqrt{2(h_1 - h_2)} = 381.8 \text{ m/s}$$

13. An insulated chamber receives 2kg/s R-134a at 1 MPa, 100°c in a line with a low velocity. Another line with R-134a as saturated liquid, 600c flows through a valve to the mixing chamber at 1 Mpa after the valve. The exit flow is saturated vapor at 1Mpa flowing at 20-m/s. Find the flow rate for the second line.

Solution:

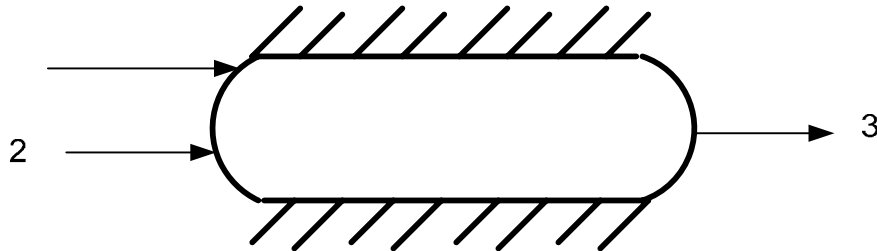

$$Q=0; W=0;$$

$$SFEE = 0 = m_3 (h_3) + c_3^2/2 - (m_1 h_1 + m_2 h_2)$$

$$m_1 = 2 \text{ g/s} \quad h_1 (1 \text{ Mpa}, 100^\circ \text{C}) = 483.36 \cdot 10^3 \text{ J/kg}$$

$$m_2 = ? \quad h_2 (\text{saturated liquid } 60^\circ \text{C}) = 287.79 \cdot 10^3 \text{ J/kg}$$

$$m_3 = ? \quad h_3 (\text{saturated vapor } 1 \text{ Mpa}) = 419.54 \cdot 10^3 \text{ J/kg}$$

$$m_3 \left[419540 + \frac{400}{2} \right] = 2 \cdot 483360 + m_2 (287790)$$

$$419.74 m_3 = 966.72 + 287.79 m_2$$

$$1.458 m_3 = 3.359 + m_2$$

$$\underline{m_3 = \frac{2 + m_2}{0.458}}$$

$$0.458 m_3 = 1.359$$

$$m_3 = 2.967 \text{ kg/s} ; \quad m_2 = 0.967 \text{ kg/s}$$

14. A small, high-speed turbine operating on compressed air produces a power output of 100W. The inlet state is 400 kPa, 50°C, and the exit state is 150 kPa, 30°C. Assuming the velocities to be low and the process to be adiabatic, find the required mass flow rate of air through the turbine.

Solution:

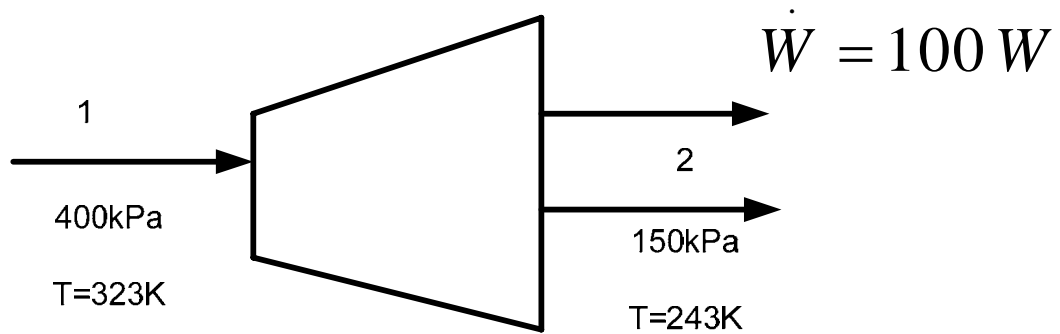

$$\text{SFEE : } -100 = \dot{m} [h_2 - h_1]$$

$$h_1 = 243 \cdot c_p$$

$$h_2 = 323 \cdot c_p$$

$$-100 = \dot{m} c_p (243 - 323)$$

$$\dot{m} c_p = 1.25$$

$$\dot{m} = 1.25 \cdot 10^{-3} \text{ kg/s}$$

15. The compressor of a large gas turbine receives air from the ambient at 95 kPa, 20°C, with a low velocity. At the compressor discharge, air exists at 1.52 MPa, 430°C, with a velocity of 90-m/s. The power input to the compressor is 5000 kW. Determine the mass flow rate of air through the unit.

Solution:

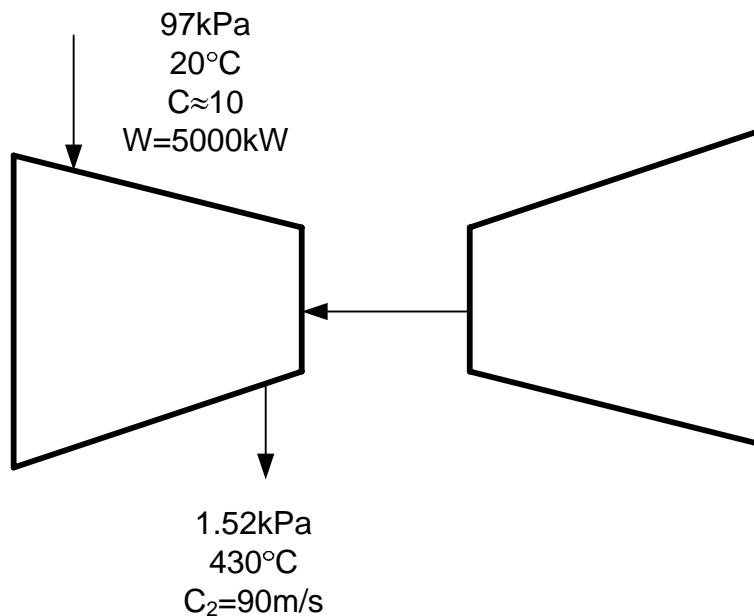

Assume that compressor is insulated. $Q=0$;

$$\text{SFEE: } 5000 \times 10^3 = \dot{m} \left[1000 \times 430 + \frac{90^2}{2} - 1000 \times 20 \right]$$

$$5000 = \dot{m} [410 - 4.05]$$

$$\dot{m} = 12.3 \text{ kg/s}$$

16. In a steam power plant 1 MW is added at 700°C in the boiler , 0.58 MW is taken at out at 40°C in the condenser, and the pump work is 0.02 MW. Find the plant thermal efficiency. Assuming the same pump work and heat transfer to the boiler is given, how much turbine power could be produced if the plant were running in a Carnot cycle?

Solution:

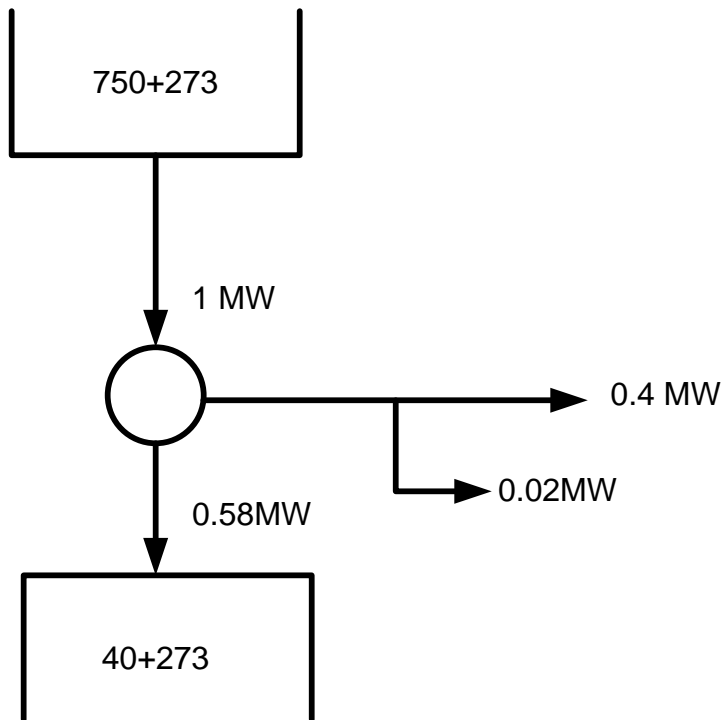

$$\eta = 1 - \frac{313}{1023} = 0.694$$

Theoretically 0.694 MW could have been generated. So OK on Carnot cycle

Power= 0.694 W

17. A car engine burns 5 kg fuel at 1500 K and rejects energy into the radiator and exhaust at an average temperature of 750 K. If the fuel provides 40000 kJ/kg, what is the maximum amount of work the engine provide?

Solution:

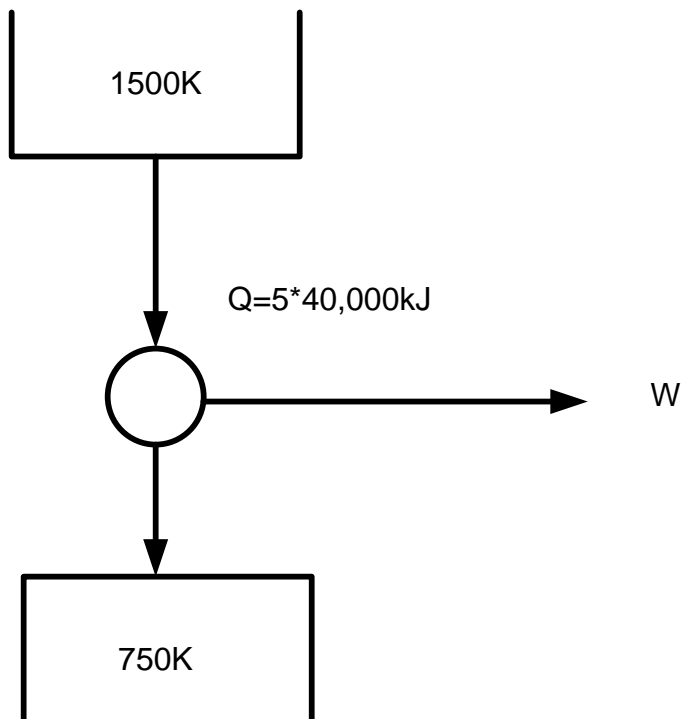

$$\eta = \frac{T_1 - T_2}{T_1} = 50 \%$$

$$W = 20,000 \cdot 5 = 10^5 \text{ KJ} = 100 \text{ MJ}$$

18. At certain locations geothermal energy in underground water is available and used as the energy source for a power plant. Consider a supply of saturated liquid water at 150°C. What is the maximum possible thermal efficiency of a cyclic heat engine using the source of energy with the ambient at 20°C? Would it be better to locate a source of saturated vapor at 150°C than to use the saturated liquid at 150°C?

Solution:

$$\eta_{\max} = \frac{1 - 293}{423} = 0.307 \text{ or } 30.7\%$$

19. An air conditioner provides 1 kg/s of air at 15°C cooled from outside atmospheric air at 35°C. Estimate the amount of power needed to operate the air conditioner. Clearly state all the assumptions made.

Solution: assume air to be a perfect gas

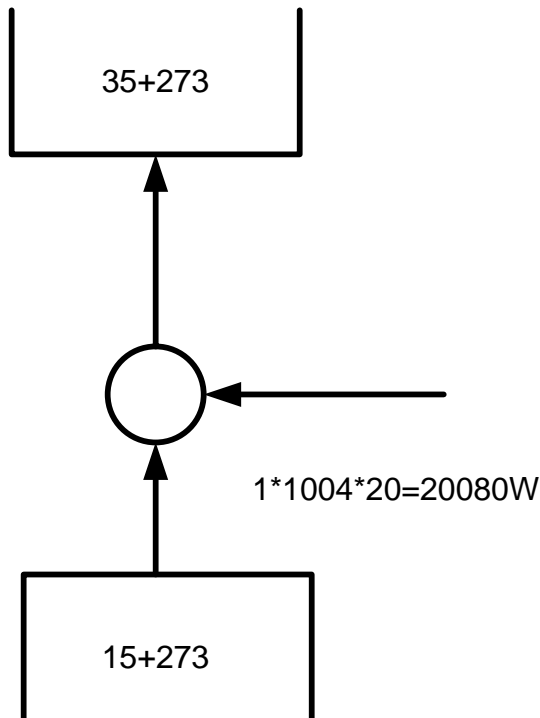

$$cop = \frac{288}{20} = 14.4$$

$$W = \frac{20080}{14.4} = 1390 \text{ W}$$

20. We propose to heat a house in the winter with a heat pump. The house is to be maintained at 20°C at all times. When the ambient temperature outside drops at -10°C that rate at which heat is lost from the house is estimated to be 25 KW . What is the minimum electrical power required to drive the heat pump?

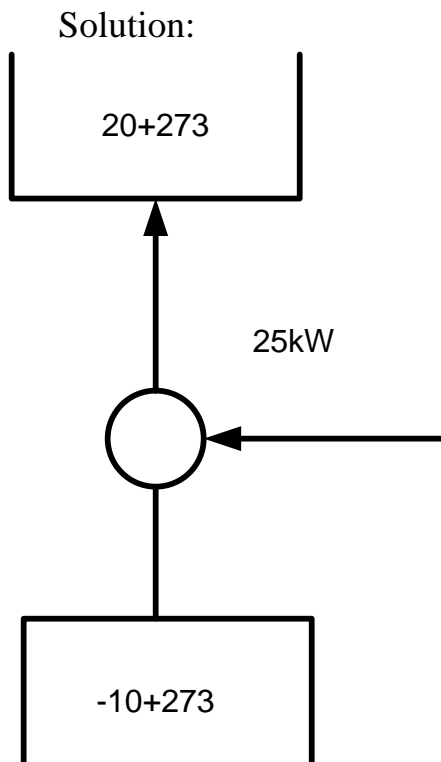

$$\text{cop}_{Hp} = \frac{293}{30} = 9.77$$

$$W = \frac{25}{9.71} = 2.56 \text{ KW}$$

21. A household freezer operates in a room at 20°C . Heat must be transferred from the cold space at a rate of 2 kW to maintain its temperature at -30°C . What is the theoretically smallest (power) motor required to operate this freezer?

Solution:

$$cop = \frac{243}{50} = 4.86$$

$$W = \frac{2}{4.86} = 0.41\text{ kW}$$

22. Differences in surface water and deep-water temperature can be utilized for power generation. It is proposed to construct a cyclic heat engine that will operate near Hawaii, where the ocean temperature is 20°C near the surface and 5°C at some depth. What is the possible thermal efficiency of such a heat engine?

Solution:

$$\eta_{\max} = \frac{15}{293} = 5\%$$

23. We wish to produce refrigeration at -30°C . A reservoir, shown in fig is available at 200°C and the ambient temperature is 30°C . This, work can be done by a cyclic heat engine operating between the 200°C reservoir and the ambient. This work is used to drive the refrigerator. Determine the ratio of heat transferred from 200°C reservoir to the heat transferred from the -30°C reservoir, assuming all process are reversible.

Solution:

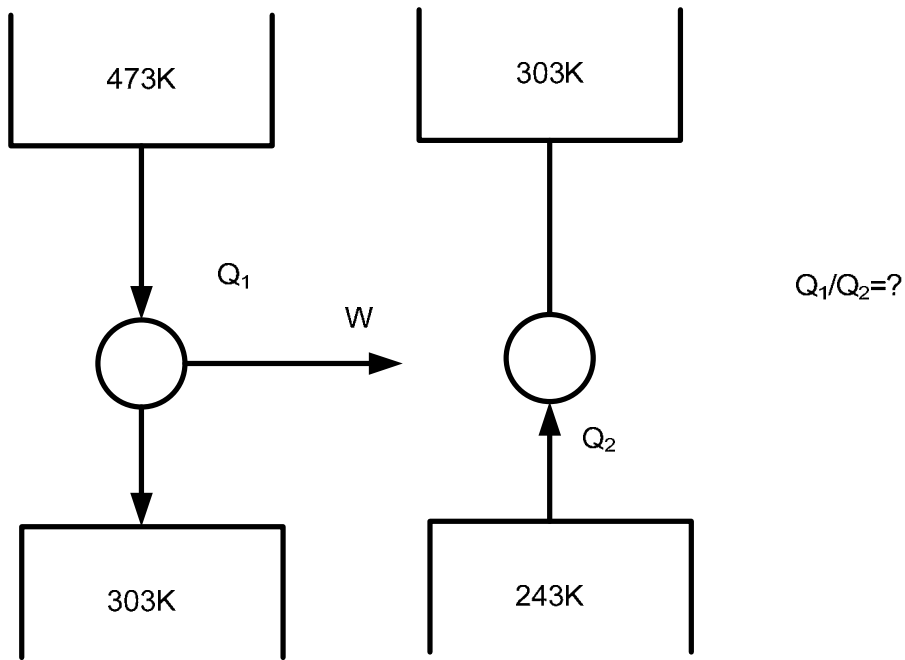

$$\eta=0.359$$

$$cop=4.05$$

$$W = Q * 0.3594$$

$$Q_2 = W * 4.05$$

$$W = \frac{Q_2}{4.05}$$

$$Q_1 * 0.3594 = \frac{Q_2}{6.05}$$

$$\frac{Q_1}{Q_2} = \frac{1}{4.05 * 0.3594} = 0.69$$

24. Nitrogen at 600 kPa, 127 °C is in a 0.5m³-insulated tank connected to pipe with a valve to a second insulated initially empty tank 0.5 m³. The valve is opened and nitrogen fills both the tanks. Find the final pressure and temperature and the entropy generation this process causes. Why is the process irreversible?

Solution:

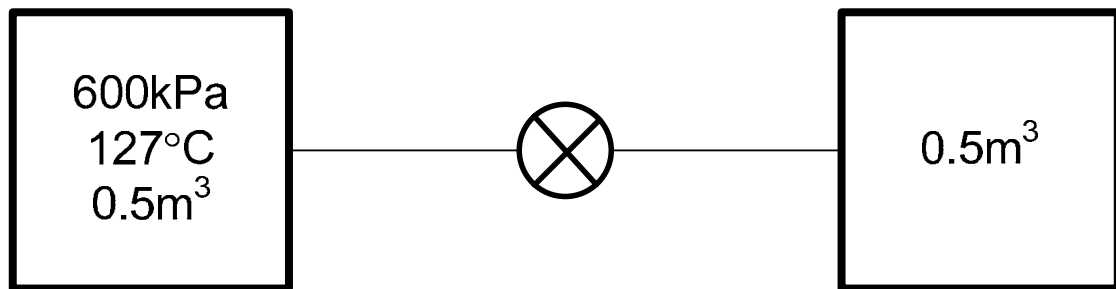

Final pressure = 300 kPa

Final temperature=127 kPa as it will be a throttling process and h is constant.

T= constant for ideal gas

$$m = \frac{10^3 * 600 * 0.5}{\frac{8314}{28} * 400} = \frac{750 * 28}{8314} = 2.5 \text{ kg}$$

$$\begin{aligned} \Delta s \text{ for an isothermal process} &= mR \ln \frac{V_2}{V_1} \\ &= 2.5 * \frac{5314}{28} \text{ m}^2 \\ &= 514.5 \text{ J/k} \end{aligned}$$

25. A mass of a kg of air contained in a cylinder at 1.5Mpa, 100K , expands in a reversible isothermal process to a volume 10 times larger. Calculate the heat transfer during the process and the change of entropy of the air.

Solution:

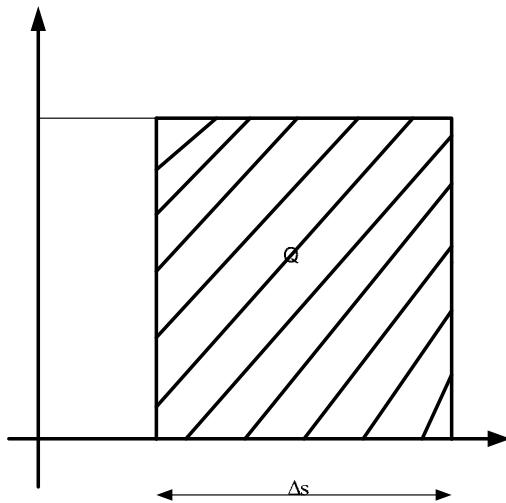
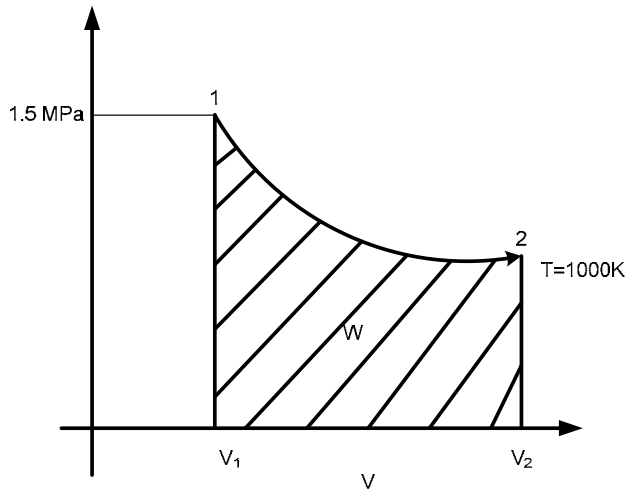

$$V_2 = 10V_1$$

$$Q = W = p_1 v_1 \ln \frac{v_2}{v_1}$$

For isothermal process

$$= mRT_1 \ln \frac{v_2}{v_1}$$

$$= 1 * \frac{8314}{29} * 1000 * \ln 10 = 660127 \text{ J}$$

W=Q for an isothermal process,

$$T\Delta s = 660127;$$

$$\Delta s = 660 \text{ J/K}$$

26. A rigid tank contains 2 kg of air at 200 kPa and ambient temperature, 20°C. An electric current now passes through a resistor inside the tank. After a total of 100 kJ of electrical work has crossed the boundary, the air temperature inside is 80°C, is this possible?

Solution:

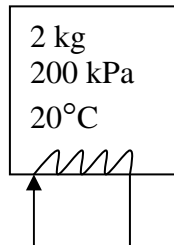

$$Q = 100 \times 10^3 \text{ J}$$

It is a constant volume process.

$$Q = mc_v \Delta T$$

$$= 2 \times 707 \times 20$$

$$= 83840 \text{ J}$$

Q given 10,000 Joules only. Therefore not possible because some could have been lost through the wall as they are not insulated.

$$\Delta S_{air} = \int_{293}^{353} \frac{mc_v dT}{T} = 2 \times 703 \ln \frac{353}{293} = 261.93 \text{ J/K}$$

$$\Delta S_{sun} = \frac{-100 \times 10^3}{293} = -3413 \text{ J/K}$$

$$\Delta_{system} + \Delta_{sun} < 0$$

Hence not possible. It should be ≥ 0 ;

27. A cylinder/ piston contain 100 L of air at 110 kPa, 25°C. The air is compressed in reversible polytropic process to a final state of 800 kPa, 200°C. Assume the heat transfer is with the ambient at 25°C and determine the polytropic exponent n and the final volume of air. Find the work done by the air, the heat transfer and the total entropy generation for the process.

Solution:

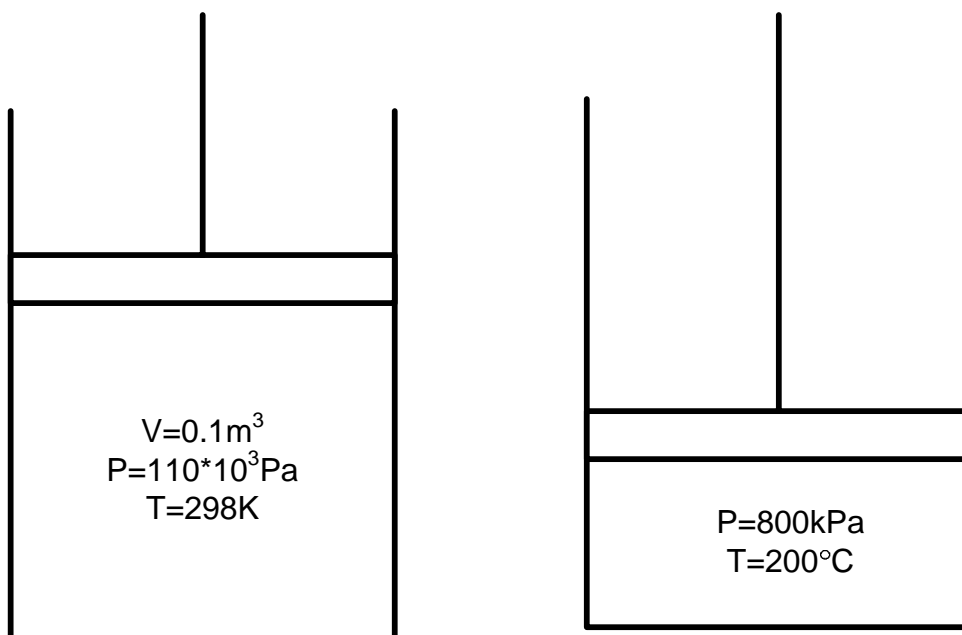

$$\frac{p_1 V_1}{T_1} = \frac{p_2 V_2}{T_2} = \frac{110 \times 10^3 * 0.1}{298} = \frac{800 \times 10^3 * V_2}{473} = V_2 = 0.022 \text{ m}^3$$

$$p_1 * V^{\gamma_1} = p_2 * V_2^{\gamma}$$

$$\left(\frac{p_1}{p_2} \right) = \left(\frac{V_2}{V_1} \right)^{\gamma}$$

$$7.273 = (4.545)^{\gamma}$$

$$\gamma = 1.31$$

$$W = \frac{p_1 V_1 - p_2 V_2}{n-1} = \frac{110 * 10^3 * 0.1 - 800 * 0.022 * 10^3}{1.31-1} = -21290J$$

$$\Delta S = R \ln \frac{V_2}{V_1} + c_v \ln \frac{T_1}{T_2}$$

$$= \frac{8314}{29} \ln \frac{0.022}{0.1} + \frac{8314}{29 * 1.48} \ln \frac{473}{298} = -103J / kgK$$

$$m = \frac{110 * 10^3 * 0.1}{\frac{8314}{29} * 298} = 0.129kg$$

$$\Delta S = -13.28J / K$$

$$\Delta U = 0.129 * \frac{8314}{29 * 0.4} (473 - 298) = 16180J$$

$$Q - W = \Delta U$$

$$Q = 16180 - 21290 = -5110J$$

28. A closed, partly insulated cylinder divided by an insulated piston contains air in one side and water on the other, as shown in fig. There is no insulation on the end containing water. Each volume is initially 100L, with the air at 40°C and the water at 90°C, quality 10 %. Heat is slowly transferred to the water, until a final pressure of 500kPa. Calculate the amount of heat transferred.

Solution:

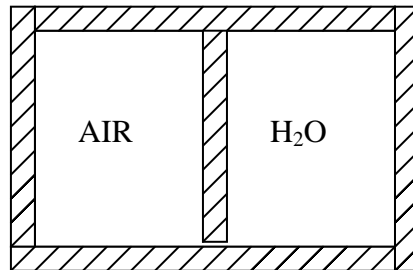

State 1:

$$V_{\text{air}}=0.1\text{m}^3$$

$$t_{\text{air}}=40^\circ\text{C}$$

$$V_{\text{water}}=0.1\text{m}^3$$

$$x=0.1$$

$$\text{Total volume}=0.2\text{m}^3$$

$$t_{\text{water}}=90^\circ\text{C}$$

Initial pressure of air = saturation pressure of water at 90°C = 70.14kPa

$$v_g/90^\circ\text{C} = 2.360506\text{m}^3/\text{kg}$$

$$v_f/90^\circ\text{C} = 0.0010316\text{m}^3/\text{kg}$$

$$V = xv_g + (1-x)v_f$$

$$= 0.1 * 2.36056 + 0.9 * 0.0010316 = 0.237\text{m}^3/\text{kg}$$

$$V = 0.1\text{m}^3$$

$$m_{\text{water}} = \frac{V}{v} = \frac{0.1}{0.237} = 0.422\text{kg}$$

State 2:

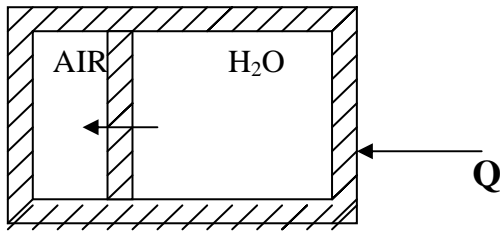

Assume that compression of air is reversible. It is adiabatic

$$p_1 V_1^\gamma = p_2 V_2^\gamma$$

$$V_2 = V_1 \left(\frac{p_1}{p_2} \right)^{\frac{1}{\gamma}} = 0.1 \left(\frac{70.14}{500} \right)^{\frac{1}{1.4}} = 0.0246 \text{ m}^3$$

$$\text{Volume of water chamber} = 0.2 - 0.0246 = 0.1754 \text{ m}^3$$

$$\text{Specific volume} = \frac{0.1754}{0.422} = 0.416 \text{ m}^3 / \text{kg}$$

$$v_g /_{500 \text{ kPa}} = 0.3738 \text{ m}^3 / \text{kg}$$

Therefore steam is in superheated state.

<http://courses.arch.hku.hk/IntgBuildTech/SBT99/SBT99-03/index.htm>
http://tigger.uic.edu/~mansoori/Thermodynamic.Data.and.Property_html
<http://birger.maskin.ntnu.no/kkt/grzifk/java/PsychProJava.html>
<http://oldsci.eiu.edu/physics/DDavis/1150/14Thermo/ToC.html>
http://tigger.uic.edu/~mansoori/Thermodynamics.Educational.Sites_html
<http://www.kkt.ntnu.no/kkt2/courses/sio7050/index.html>
<http://ergo.human.cornell.edu/studentdownloads/DEA350notes/Thermal/thperfnotes.html>
<http://www.cs.rutgers.edu/~vishukla/Thermo/therm.html>
http://www.colorado.edu/MCEN/Thermo/Lecture_1.pdf
<http://thermal.sdsu.edu/testcenter/Test/problems/chapter03/chapter03.html>
http://www.innovatia.com/Design_Center/rktprop1.htm
<http://courses.washington.edu/mengr430/handouts/availability.pdf>
<http://www.duke.edu/~dalott/ns12.html>
<http://www.eng.fsu.edu/~shih/eml3015/lecture%20notes/>
<http://www.mech.uq.edu.au/courses/mech3400/lecture-notes/lecture-notes.html>
http://www.chemeng.mcmaster.ca/courses/che4n4/BoilerHouse/WEB_BoilerHouse_page.htm

HEAT TRANSFER

<http://home.olemiss.edu/~cmprice/lectures/>
<http://www.me.rochester.edu:8080/courses/ME223/lecture/>
<http://www.nd.edu/~msen/Teaching/IntHT/Notes.pdf>
<http://muse.widener.edu/~jem0002/me455f01/me455.html>
http://www.che.utexas.edu/cache/trc/t_heat.html
<http://www.onesmartclick.com/engineering/fluid-mechanics.html>
<http://www.mem.odu.edu/me315/lectures.html>
<http://www.ttiedu.com/236cat.html>
<http://ceprofs.tamu.edu/hchen/engr212/>

REFRIGERATION

<http://www.afns.ualberta.ca/foodeng/nufs353/lectures/>
http://www.tufts.edu/as/tampl/en43/lecture_notes/ch8.html
<http://www.mme.tcd.ie/~johnnc/3B1/3B1.html>
<http://www.uni-konstanz.de/physik/Jaeckle/papers/thermopower/node7.html>

www.onesmartclick.com/engineering/heat-transfer.html

Mixtures

<http://imartinez.etsin.upm.es/bk3/c07/mixtures.htm>

Fugacity

http://www.public.asu.edu/~laserweb/woodbury/classes/chm341/lecture_set7/lecture7.html

<http://puccini.che.pitt.edu/~karlj/Classes/CHE1007/106notes/106notes.html>

<http://puccini.che.pitt.edu/~karlj/Classes/CHE1007/106notes/106notes.html>