

Test Paper : II
Test Subject : ELECTRONIC SCIENCE
Test Subject Code : K-3114

Test Booklet Serial No. : _____
OMR Sheet No. : _____
Roll No.

--	--	--	--	--	--	--	--

(Figures as per admission card)

Name & Signature of Invigilator/s

Signature: _____
Name : _____

Signature: _____
Name : _____

Paper : II
Subject : ELECTRONIC SCIENCE

Time : 1 Hour 15 Minutes

Maximum Marks : 100

Number of Pages in this Booklet : 8

Number of Questions in this Booklet : 50

ಅಭ್ಯರ್ಥಿಗಳಿಗೆ ಸೂಚನೆಗಳು

- ಈ ಪುಟದ ಮೇಲ್ಭಾಗದಲ್ಲಿ ಒದಗಿಸಿದ ಸ್ಥಳದಲ್ಲಿ ನಿಮ್ಮ ರೋಲ್ ನಂಬರನ್ನು ಬರೆಯಿರಿ.
- ಈ ಪತ್ರಿಕೆಯು ಬಹು ಆಯ್ಕೆ ವಿಧದ ಐವತ್ತು ಪ್ರಶ್ನೆಗಳನ್ನು ಒಳಗೊಂಡಿದೆ.
- ಪರೀಕ್ಷೆಯ ಪ್ರಾರಂಭದಲ್ಲಿ ಪ್ರಶ್ನೆಪುಸ್ತಕವನ್ನು ನಿಮಗೆ ನೀಡಲಾಗುವುದು. ಮೊದಲ 5 ನಿಮಿಷಗಳಲ್ಲಿ ನೀವು ಪುಸ್ತಕವನ್ನು ತೆರೆಯಲು ಮತ್ತು ಕೆಳಗಿನಂತೆ ಕಡ್ಡಾಯವಾಗಿ ಪರಿಶೀಲನೆ ಕೋರಲಾಗಿದೆ.
(i) ಪ್ರಶ್ನೆಪುಸ್ತಕದ ಪ್ರವೇಶಾಪಕಾಶ ಪಡೆಯಲು, ಈ ಹೊದಿಕೆ ಪುಟದ ಅಂಚಿನ ಮೇಲಿರುವ ಪೇಪರ್ ಸೀಲನ್ನು ಹರಿಯಿರಿ. ಸ್ವಿಚ್ಚರ್ ಸೀಲ್ ಇಲ್ಲದ ಪ್ರಶ್ನೆಪುಸ್ತಕ ಸ್ವೀಕರಿಸಬೇಡಿ. ತೆರೆದ ಪುಸ್ತಕವನ್ನು ಸ್ವೀಕರಿಸಬೇಡಿ.
(ii) ಪುಸ್ತಕಿಯಲ್ಲಿನ ಪ್ರಶ್ನೆಗಳ ಸಂಖ್ಯೆ ಮತ್ತು ಪುಟಗಳ ಸಂಖ್ಯೆಯನ್ನು ಮುಖಪುಟದ ಮೇಲೆ ಮುದ್ರಿಸಿದ ಮಾಹಿತಿಯೊಂದಿಗೆ ತಾಳೆ ನೋಡಿ. ಪುಟಗಳು/ಪ್ರಶ್ನೆಗಳು ಕಾಣೆಯಾದ, ಅಥವಾ ದ್ವಿಪ್ರತಿ ಅಥವಾ ಅನುಕ್ರಮವಾಗಿಲ್ಲದ ಅಥವಾ ಇತರ ಯಾವುದೇ ವ್ಯತ್ಯಾಸದ ದೋಷಪೂರಿತ ಪುಸ್ತಕವನ್ನು ಕೂಡಲೇ ನಿಮಿಷದ ಅವಧಿ ಒಳಗೆ, ಸಂವೀಕ್ಷಕರಿಂದ ಸರಿ ಇರುವ ಪುಸ್ತಕಕ್ಕೆ ಬದಲಾಯಿಸಿಕೊಳ್ಳಬೇಕು. ಆ ಬಳಿಕ ಪ್ರಶ್ನೆ ಪತ್ರಿಕೆಯನ್ನು ಬದಲಾಯಿಸಲಾಗುವುದಿಲ್ಲ, ಯಾವುದೇ ಹೆಚ್ಚು ಸಮಯವನ್ನೂ ಕೊಡಲಾಗುವುದಿಲ್ಲ.
- ಪ್ರತಿಯೊಂದು ಪ್ರಶ್ನೆಗೂ (A), (B), (C) ಮತ್ತು (D) ಎಂದು ಗುರುತಿಸಿದ ನಾಲ್ಕು ಪರ್ಯಾಯ ಉತ್ತರಗಳಿವೆ. ನೀವು ಪ್ರಶ್ನೆಯ ಎದುರು ಸರಿಯಾದ ಉತ್ತರದ ಮೇಲೆ, ಕೆಳಗೆ ಕಾಣಿಸಿದಂತೆ ಅಂಡಾಕೃತಿಯನ್ನು ಕಪ್ಪಾಗಿಸಬೇಕು.
ಉದಾಹರಣೆ:

A	B	●	D
---	---	---	---

(C) ಸರಿಯಾದ ಉತ್ತರವಾಗಿದ್ದಾಗ.
- ಪ್ರಶ್ನೆ ಪತ್ರಿಕೆ I ರಲ್ಲಿ ಕೊಟ್ಟಿರುವ OMR ಉತ್ತರ ಹಾಳೆಯಲ್ಲಿ, ಪ್ರಶ್ನೆ ಪತ್ರಿಕೆ I ಮತ್ತು ಪ್ರಶ್ನೆ ಪತ್ರಿಕೆ II ರಲ್ಲಿ ಇರುವ ಪ್ರಶ್ನೆಗಳಿಗೆ ನಿಮ್ಮ ಉತ್ತರಗಳನ್ನು ಸೂಚಿಸತಕ್ಕದ್ದು. OMR ಉತ್ತರ ಹಾಳೆಯಲ್ಲಿ ಅಂಡಾಕೃತಿಯಲ್ಲದೆ ಬೇರೆ ಯಾವುದೇ ಸ್ಥಳದಲ್ಲಿ ಉತ್ತರವನ್ನು ಗುರುತಿಸಿದರೆ, ಅದರ ಮೌಲ್ಯಮಾಪನ ಮಾಡಲಾಗುವುದಿಲ್ಲ.
- OMR ಉತ್ತರ ಹಾಳೆಯಲ್ಲಿ ಕೊಟ್ಟ ಸೂಚನೆಗಳನ್ನು ಜಾಗರೂಕತೆಯಿಂದ ಓದಿರಿ.
- ಎಲ್ಲಾ ಕರಡು ಕೆಲಸವನ್ನು ಪುಸ್ತಕಿಯ ಕೊನೆಯಲ್ಲಿ ಮಾಡತಕ್ಕದ್ದು.
- ನಿಮ್ಮ ಗುರುತನ್ನು ಬಹಿರಂಗಪಡಿಸಬಹುದಾದ ನಿಮ್ಮ ಹೆಸರು ಅಥವಾ ಯಾವುದೇ ಚಿಹ್ನೆಯನ್ನು ಸಂಗತವಾದ ಸ್ಥಳ ಹೊರತು ಪಡಿಸಿ, OMR ಉತ್ತರ ಹಾಳೆಯ ಯಾವುದೇ ಭಾಗದಲ್ಲಿ ಬರೆಯಬೇಡಿ, ನೀವು ಅನರ್ಹತೆಗೆ ಬಾಧ್ಯರಾಗಿರುತ್ತೀರಿ.
- ಪರೀಕ್ಷೆಯ ಮುಗಿದನಂತರ, ಕಡ್ಡಾಯವಾಗಿ OMR ಉತ್ತರ ಹಾಳೆಯನ್ನು ಸಂವೀಕ್ಷಕರಿಗೆ ನೀವು ಹಿಂತಿರುಗಿಸಬೇಕು ಮತ್ತು ಪರೀಕ್ಷಾ ಕೊಠಡಿಯ ಹೊರಗೆ OMR ನ್ನು ನಿಮ್ಮೊಂದಿಗೆ ಕೊಂಡೊಯ್ಯ ಕೂಡದು.
- ಪರೀಕ್ಷೆಯ ನಂತರ, ಪರೀಕ್ಷಾ ಪ್ರಶ್ನೆಪತ್ರಿಕೆಯನ್ನು ಮತ್ತು ನಕಲು OMR ಉತ್ತರ ಹಾಳೆಯನ್ನು ನಿಮ್ಮೊಂದಿಗೆ ತೆಗೆದುಕೊಂಡು ಹೋಗಬಹುದು.
- ನೀಲಿ/ಕಪ್ಪು ಬಾಲ್ ಪಾಯಿಂಟ್ ಪೆನ್ ಮಾತ್ರವೇ ಉಪಯೋಗಿಸಿರಿ.
- ಕ್ಯಾಲ್ಕುಲೇಟರ್ ಅಥವಾ ಲಾಗ್ ಟೇಬಲ್ ಇತ್ಯಾದಿಯ ಉಪಯೋಗವನ್ನು ನಿಷೇಧಿಸಲಾಗಿದೆ.
- ಸರಿ ಅಲ್ಲದ ಉತ್ತರಗಳಿಗೆ ಋಣ ಅಂಕ ಇರುವುದಿಲ್ಲ.

Instructions for the Candidates

- Write your roll number in the space provided on the top of this page.
- This paper consists of fifty multiple-choice type of questions.
- At the commencement of examination, the question booklet will be given to you. In the first 5 minutes, you are requested to open the booklet and compulsorily examine it as below :
(i) To have access to the Question Booklet, tear off the paper seal on the edge of this cover page. Do not accept a booklet without sticker-seal and do not accept an open booklet.
(ii) **Tally the number of pages and number of questions in the booklet with the information printed on the cover page. Faulty booklets due to pages/questions missing or duplicate or not in serial order or any other discrepancy should be got replaced immediately by a correct booklet from the invigilator within the period of 5 minutes. Afterwards, neither the Question Booklet will be replaced nor any extra time will be given.**
- Each item has four alternative responses marked (A), (B), (C) and (D). You have to darken the oval as indicated below on the correct response against each item.
Example :

A	B	●	D
---	---	---	---

where (C) is the correct response.
- Your responses to the questions are to be indicated in the **OMR Sheet kept inside the Paper I Booklet only**. If you mark at any place other than in the ovals in the Answer Sheet, it will not be evaluated.
- Read the instructions given in OMR carefully.
- Rough Work is to be done in the end of this booklet.
- If you write your name or put any mark on any part of the OMR Answer Sheet, except for the space allotted for the relevant entries, which may disclose your identity, you will render yourself liable to disqualification.
- You have to return the test OMR Answer Sheet to the invigilators at the end of the examination compulsorily and must NOT carry it with you outside the Examination Hall.
- You can take away question booklet and carbon copy of OMR Answer Sheet soon after the examination.
- Use only Blue/Black Ball point pen.**
- Use of any calculator or log table etc., is prohibited.**
- There is no negative marks for incorrect answers.**



ELECTRONIC SCIENCE Paper – II

Note : This paper contains **fifty (50)** objective type questions. **Each** question carries **two (2)** marks. **All** questions are **compulsory**.

- Zener diode works on the principle of
(A) Tunneling of charge carriers across the junction
(B) Thermionic emission
(C) Diffusion of charge carriers across the junction
(D) Acceleration of charge carriers
- In an integrated circuit, the SiO₂ layer provides
(A) Electrical connection to external circuits
(B) Physical strength
(C) Isolation
(D) Conducting path
- For an ideal transformer
(A) Both Z and Y parameters exist
(B) Neither Z nor Y parameters exist
(C) Z-parameter exist but not the Y-parameter
(D) Y-parameter exist but not the Z-parameter
- What is the current supplied by 1V source when each resistance is 1 ohm ?

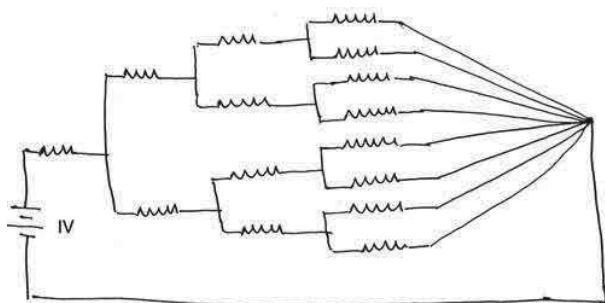

- (A) 8/15 (B) 15/4
(C) 4/15 (D) 6/15

- Out of the following, which statement doesnot hold good in case of sample and hold circuit
(A) Sample time is much smaller than hold time.
(B) Aperture time is the delay between the time that the pulse is applied to the switch and the actual time the switch closes.
(C) Acquisition time is the time it takes for the capacitor to charge from one voltage to another voltage.
(D) The voltage across the hold capacitor changes by 50% during the hold time.
- Hysteresis is desirable in Schmitt-trigger, because
(A) Energy is to be stored/discharged in parasitic capacitances
(B) Effects of temperature would be compensated
(C) Devices in the circuit should be allowed time for saturation and desaturation
(D) It would increase the speed of triggering

- Point out the mismatch
(A) Ring Counter (B) Shift Register
(C) JK flip-flop (D) Decoder
- The output $f(x, y)$ of multiplexer resembles the behaviour of _____ gate.

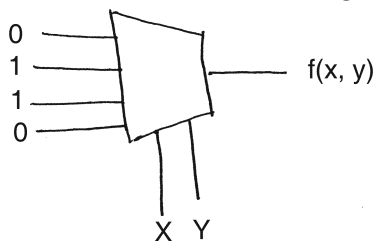

- (A) NOR (B) EX-OR
(C) AND (D) NAND



9. LOCK prefix is used most often in case of 8086 microprocessor
- (A) During normal execution
 - (B) During DMA accesses
 - (C) During interrupt servicing
 - (D) During memory accesses
10. DMA transfer implies
- (A) Direct transfer of data between memory and accumulator
 - (B) Direct transfer of data between memory and I/O devices without the use of microprocessor
 - (C) Transfer of data exclusively within microprocessor register
 - (D) A fast transfer of data between microprocessor and I/O devices
11. What is the output of the following 'C' code ?
- ```
#include<stdio.h>
void main ()
{
 int s = 0;
 while (s++<10)
 {
 if(s<4 && s<9)
 continue;
 printf ("\n%d\t",s);
 }
}
```
- (A) 1 2 3 4 5 6 7 8 9
  - (B) 1 2 3 1 0
  - (C) 4 5 6 7 8 9
  - (D) 4 5 6 7 8 9 10
12. What will be the output of the following statements ?
- ```
int a = 5, b = 2, c = 10, i = a > b
void main ( )
{printf("hello"); main ( );}
```
- (A) 1
 - (B) 2
 - (C) Infinite number of times
 - (D) 10
13. The cut off frequency for a rectangular wave guide of dimension $2 \times 1 \text{ cm}^2$ is
- (A) 750 MHz
 - (B) 7.5 GHz
 - (C) 75 MHz
 - (D) 0.7 GHz
14. A transmission line of characteristic impedance of 50Ω is cut into two halves. The characteristic impedance of each of the line is
- (A) 25Ω
 - (B) 100Ω
 - (C) 50Ω
 - (D) 12.5Ω
15. Point out the mismatch amongst the following modulation techniques.
- (A) PCM
 - (B) Delta
 - (C) Adaptive Delta
 - (D) FM
16. On-off keying is a special case of
- (A) PSK
 - (B) ASK
 - (C) QPSK
 - (D) FSK
17. A motor which can conveniently be operated at lagging as well as leading power factors is the
- (A) Squirrel case induction motor
 - (B) Wound rotor induction motor
 - (C) Synchronous motor
 - (D) DC shunt motor
18. Following is not quantum device.
- (A) LDR
 - (B) Photodiode
 - (C) Photo transistor
 - (D) PIN diode
19. Identify the active transducer
- (A) Thermistor
 - (B) Thermocouple
 - (C) Strain gauge
 - (D) Capacitance
20. Of the following, which one is not a Hurwitz polynomial ?
- (A) $(S + 1)(S^2 + 2S + 3)$
 - (B) $(S^3 + 3S) \left(1 + \frac{2}{S}\right)$
 - (C) $(S + 3)(S^2 + S - 2)$
 - (D) $(S + 1)(S + 2)(S + 3)$



Directions : Q. No. (s) 21 to 30 : The following items consist of two statements, one labelled the "Assertion (A)" and the other labelled the "Reason (R)". You are to examine these two statements carefully and decide if the Assertion (A) and the Reason (R) are individually true and if so, whether the Reason is a correct explanation of the Assertion. Select your answers to these items using the codes given below and mark your answer accordingly.

Codes :

- (A) Both (A) and (R) are true and (R) is the correct explanation of (A)
- (B) Both (A) and (R) are true, but (R) is not correct explanation of (A)
- (C) (A) is true, but (R) is false
- (D) (A) is false, but (R) is true

21. Assertion (A) : For same drain current rating N-channel MOSFET occupies more area than P-channel MOSFET.

Reason (R) : Electron mobility is much higher than hole mobility.

22. Assertion (A) : An unbiased p-n junction develops a built in potential at the junction with the n-side positive and the p-side negative.

Reason (R) : The p-n junction behaves as a battery and supplies current to a resistance connected across its terminals.

23. Assertion (A) : The Kirchoff's current law states that the sum of currents entering at any node is equal to the sum of currents leaving that node.

Reason (R) : The Kirchoff's current law is based on the law of conservation of charge.

24. Assertion (A) : Master slave J-K flip-flop is preferred to an edge-triggered J-K flip-flop in high speed circuits.

Reason (R) : Master slave J-K flip-flop is free from race around problem.

25. Assertion (A) : 8085 is an 8-bit microprocessor.

Reason (R) : Most of the general purpose registers in 8085 are 8-bit.

26. Assertion (A) : In 'C' language pointers are used for accessing arrays or string elements.

Reason (R) : The correct syntax in C to declare a float pointer is * float ptr;

27. Assertion (A) : $\nabla \cdot B = 0$.

Reason (R) : Magnetic monopoles exist in the universe.

28. Assertion (A) : AM has better noise performance than FM.

Reason (R) : AM results in increase in signal power.

29. Assertion (A) : Optocouplers have built in LED and photodetector.

Reason (R) : The optocouplers are high speed since they have LED and photodetector built on single monolithic substrate.

30. Assertion (A) : The integral control, increases the steady state error.

Reason (R) : The term reset control refers to an integral counter.

31. Consider the following statements :
A clamper circuit.

- 1) Adds or subtracts a dc voltage to a waveform.
- 2) Doesnot change the waveform
- 3) Amplifies the waveform

Choose the correct statements.

- (A) 1, 2
- (B) 1, 3
- (C) 1, 2, 3
- (D) 2, 3



32. A function generator generates following waveforms :

- 1) Sine wave
- 2) Square wave
- 3) Triangular wave

The correct sequence of waveform generation is

- (A) 2, 3, 1 (B) 3, 2, 1
- (C) 1, 2, 3 (D) 1, 3, 2

33. The interrupt in 8085 processor are

- 1) RST 6.5
- 2) RST 5.5
- 3) TRAP
- 4) RSTO

Choose the sequence from least priority to highest priority.

- (A) 3, 1, 2, 4 (B) 4, 1, 2, 3
- (C) 4, 2, 1, 3 (D) 3, 4, 2, 1

34. In a normal microwave bench following components are present.

- 1) Source
- 2) Detector
- 3) Frequency meter
- 4) Circulator

The correct sequence of components is

- (A) 1, 2, 3, 4 (B) 4, 3, 2, 1
- (C) 3, 2, 1, 4 (D) 1, 4, 3, 2

35. Following are the components in a general purpose spectrum analyser.

- 1) Attenuator
- 2) I.F. filter
- 3) Low pass filter
- 4) Mixer

Arrange the blocks in appropriate order.

- (A) 1, 3, 4, 2 (B) 1, 2, 3, 4
- (C) 4, 3, 2, 1 (D) 4, 2, 3, 1

Directions : Q. No. (s) 36 to 45 : In the following questions, match List – I and List – II and select the correct answer using the codes given below the lists :

36. List – I List – II

- | | |
|----------------------------|----------------|
| a) Intrinsic semiconductor | i) 10^{28} |
| b) Insulator | ii) 10^{22} |
| c) Extrinsic semiconductor | iii) 10^{18} |
| d) Conductor | iv) 10^{14} |

Codes :

- | | a | b | c | d |
|-----|-----|-----|-----|-----|
| (A) | i | iii | ii | iv |
| (B) | iii | iv | ii | i |
| (C) | i | ii | iii | iv |
| (D) | iv | ii | i | iii |

37. Following is table of L.T.

 List – I List – II

- | | |
|------------------------|---------------------|
| a) 1 | i) $\frac{1}{s+1}$ |
| b) t | ii) $\frac{1}{s}$ |
| c) e^{-t} | iii) $sX(s)$ |
| d) $\frac{d}{dt} x(t)$ | iv) $\frac{1}{s^2}$ |

Codes :

- | | a | b | c | d |
|-----|----|----|-----|-----|
| (A) | i | ii | iii | iv |
| (B) | iv | ii | iii | i |
| (C) | iv | i | ii | iii |
| (D) | ii | iv | i | iii |



38. List – I

- a) Output offset voltage
- b) Input bias current
- c) PSRR
- d) CMRR

List – II

- i) Poor regulation and filtering
- ii) Flow of signal in long wires
- iii) Non-zero base current of the input transistor
- iv) Output dc voltage with grounded inputs

Codes :

	a	b	c	d
(A)	i	iii	ii	iv
(B)	iv	ii	iii	i
(C)	iv	iii	i	ii
(D)	iii	ii	iv	i

39. List – I

(Type of Counters)

- a) Mod – 6
- b) Mod – 4
- c) Mod – 11
- d) Mod – 31

List – II

(No. of flip-flops required)

- i) 3
- ii) 5
- iii) 4
- iv) 2

Codes :

	a	b	c	d
(A)	i	ii	iii	iv
(B)	i	iv	iii	ii
(C)	iv	iii	ii	i
(D)	ii	iii	iv	i

40. List – I

- a) Stack pointer
- b) Flag
- c) Monitor program
- d) Program counter

List – II

- i) Negative number
- ii) Top of stack
- iii) Cleared by reset
- iv) Checks when a key is pressed

Codes :

	a	b	c	d
(A)	ii	iii	iv	i
(B)	i	ii	iii	iv
(C)	iii	ii	i	iv
(D)	ii	i	iv	iii

41. List – I

- a) &&
- b) >=
- c) a%b
- d) ++

List – II

- i) Short hand operator
- ii) Increment operator
- iii) Relational operator
- iv) Logical operator

Codes :

	a	b	c	d
(A)	iv	iii	ii	i
(B)	iv	iii	i	ii
(C)	ii	iv	i	iii
(D)	iii	iv	ii	i

42. List – I

- a) Magic tee
- b) Gunn diode
- c) Horn
- d) Power flow

List – II

- i) Poynting vector
- ii) Antenna
- iii) Microwave source
- iv) Difference signal

Codes :

	a	b	c	d
(A)	i	iii	iv	ii
(B)	iv	ii	i	iii
(C)	iii	ii	i	iv
(D)	iv	iii	ii	i

43. List – I

- a) Detection of periodic signal in noise
- b) Recovery of band limited signal from its uniformly sampled values
- c) Finer quantisation of signal
- d) Delta modulation

List – II

- i) Increase bandwidth
- ii) Slope overloaded error
- iii) Nyquist rate
- iv) Cross correlation

Codes :

	a	b	c	d
(A)	iv	iii	i	ii
(B)	i	ii	iv	iii
(C)	ii	iii	iv	i
(D)	i	ii	iii	iv



- 44.**
- | | |
|-----------------|-----------------------------|
| List – I | List – II |
| a) LED | i) Heavily doped |
| b) PIN | ii) Coherent radiation |
| c) Tunnel diode | iii) Spontaneous emission |
| d) LASER | iv) High quantum efficiency |

Codes :

	a	b	c	d
(A)	iv	ii	i	iii
(B)	iii	i	ii	iv
(C)	iii	iv	i	ii
(D)	i	ii	iii	iv

- 45.**
- | | |
|-------------------------|---------------------|
| List – I | List – II |
| a) Piezoelectric effect | i) Speech |
| b) Hall effect | ii) Vibration |
| c) Photoelectric effect | iii) Magnetic flux |
| d) Capacitance | iv) Sensitive relay |

Codes :

	a	b	c	d
(A)	iv	iii	ii	i
(B)	ii	iii	iv	i
(C)	i	ii	iii	iv
(D)	i	iii	ii	iv

Read the passage below and answer the questions 46 to 50, that follows based on your understanding of the passage.

PIN photodiode contains a layer of intrinsic semiconductor material sandwiched between p-n regions. The depletion layer is wholly contained within the-i-(intrinsic) region.

Thickness of the intrinsic region can be adjusted to produce device with optimum sensitivity and frequency response. PIN photodiode is the most common type of depletion layer photodiode.

The other class of photodiodes, avalanche photodiodes, are reverse biased p-n junction diodes that are operated at voltages above the

breakdown voltage. Current multiplication of electron hole pairs generated by the incident electromagnetic radiation occurs due to avalanche process. The photo multiplication factor is defined as the ratio of multiplied photo current to the photo current at voltage below breakdown where no avalanche multiplication takes place.

- 46.** Semiconductors are sensitive to
 (A) Heat (B) Magnetic field
 (C) Light energy (D) All of the above
- 47.** When a reverse bias is applied to a junction diode ?
 (A) Potential barrier is lowered
 (B) Majority carrier current is increased
 (C) Minority carrier current is increased
 (D) Potential barrier is raised
- 48.** Photodiode is reverse biased because
 (A) Only one side is illuminated
 (B) Majority carriers are due to reverse bias at the junction
 (C) Reverse current is small as compared to photo current
 (D) A reverse current is large as compared to photo current
- 49.** Avalanche photodiodes are preferred over PIN diodes in optical communication systems because of
 (A) Speed of operation
 (B) Higher sensitivity
 (C) Larger bandwidth
 (D) All of the above
- 50.** Photo multiplication is due to
 (A) The number of electron-hole pairs generated in intrinsic region
 (B) The avalanche process taking place in the diode
 (C) The majority charge carriers are generated by incident light
 (D) The adjustable intrinsic-i-region of photodiode



Total Number of Pages : 8

ಚಿತ್ರ ಬರಹಕ್ಕಾಗಿ ಸ್ಥಳ
Space for Rough Work