

Sample Question Paper – I

9231

Course Name :- Fabrication Engineering
Course code :- EV
Semester :- Third
Subject :- Fabrication Drawing
Duration :- 3 hours

Marks: 80

Instruction:

- 1) All the questions are compulsory.
- 2) Figures to the right indicate full marks.

Q1. Attempt the following (Any Eight)

Marks: 16

- a) What is truss? Explain its types.
- b) Draw the sketch of angular skirt support
- c) Draw ISNL 150, b=80, t=10. Give suitable corner radius.
- d) What is gusset plate and slit plate?
- e) Draw cross section diagram of plug weld and its symbol.
- f) Draw symbol for the rivet, which is drilled and fitted, at site in two views.
- g) Draw the orthographic views of check valve.
- h) Draw the symbols for
 - i) Cap
 - ii) Sleeve
- i) List the areas of application for penetration of solids.
- j) Write the nature of intersection in the following cases.
 - i) Prism to Prism
 - ii) Prism to Cylinder

Q2. Attempt any THREE

Marks: 12

- a) Fig A shows side view of two penetrating solids. State the position of both solids with H.P and V.P.
- b) Draw the symbols in FV and TV for
 - i. Gate valve
 - ii. Globe Valve
 - iii. Check Valve
 - iv. Cross Valve.
- c) Fig B Shows a double line orthographic view of a piping layout. Convert it into single line orthographic layout.
- d) A shell of 2m diameter is to be prepared from 28mm thick mild steel plates. The ends of the plates are to be welded with double V-buff weld with broad root face. Depth of the weld is 12mm from outside and 8mm from inside of the shell and weld is flush finished on either side. Represent the welding symbol on diagram.

Q3. Attempt any THREE**Marks: 12**

- a) A cylinder of base 60mm diameter and axis 100mm is resting on its base on H.P. It is penetrated by horizontal cylinder of diameter 50mm and axis 100mm such that the axis of the solids bisect each other at right angle. The axis of the penetrating solid is parallel to V.P. Draw the projection of solid, showing curves of intersections.
- b) Draw the following pipe supports.
 - i. Roller
 - ii. Bracket supported anchor.
- c) Fig C Shows orthographic layout of a piping system. Draw the single line isometric view.
- d) Draw full size cross-sectioned view of the following joint and also represent as per B.I.S.
 - i. Single U-butt weld with root face of 3mm for joining 25mm plates. Depth of the weld is 22mm.
 - ii. Butt weld between plates of 6mm thickness with raised edges. Height of raised edge is 15mm and weld penetration is 5mm.

Q4. Attempt any TWO**Marks: 16**

- a) Draw the fink truss made by angle section having span 18m and height 5m. Represent riveted joints and welded joints symbolically.
- b) A vertical tank of 2m diameters and 8m high is elevated at a height of 6m from the ground to center of the tank. Prepare erection drawing by using bracket support (4 Nos.) Of Isection.
- c) A cylinder of diameter 70mm and axis 100mm is resting on its base on the ground. It is penetrated by a horizontal triangular prism of 60mm side and 90mm length such that the axis of the prism is parallel to V.P and 10mm in front of the axis of the cylinder and one of the face of the prism is inclined at 45° to V.P. Draw the projection of solid showing curves of intersections.

Q5. Attempt any THREE**Marks: 12**

- a) Show by neat proportionate sketches when a column ISLB 200 is connected to similar column.
- b) Draw single line developed view for the piping system shown in Fig.(C).
- c) Draw free hand sketch of a riveted base gusseted for a column (Two views)
- d) Make a proportionate sketch of plate girder.

Q6. Attempt any THREE

Marks: 12

- a) A double riveted double strap zigzag butt joint is made for 6mm thick plates. Strap thickness is 4mm. Hole for rivets are drilled at site and rivets are also fitted at site. Prepare the symbolic drawing for the joint.
- b) A beam ISMB 200 is to be connected to a column of ISMB 300, at the flange. Show the joints in two views with free hand proportionate sketch.
- c) Referring fig.(C) prepare Bill of material
- d) Write the application of the following
 - i. Fink truss
 - ii. Plate girders
 - iii. Plate type saddle supports
 - iv. Straight Skirt Support.

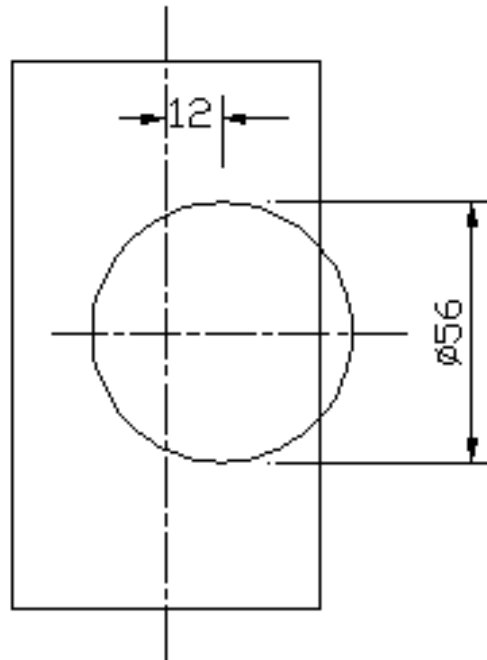

Fig. A (Q. no. 2a)

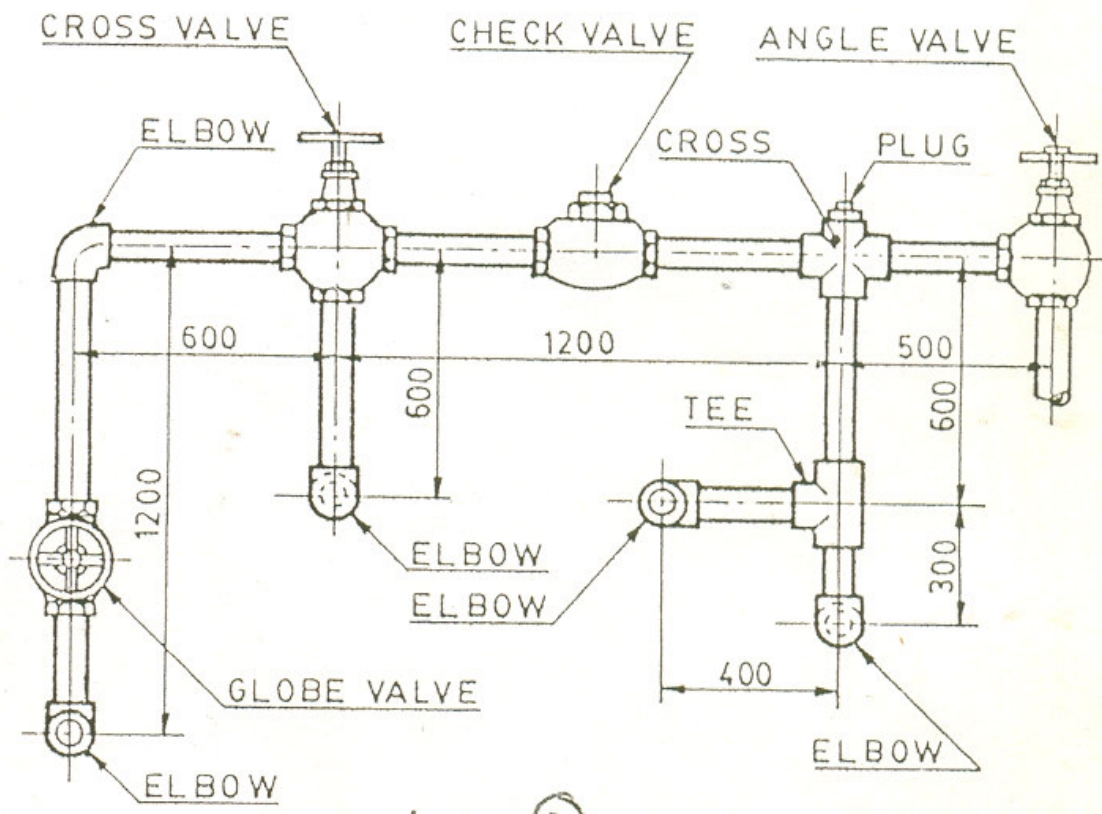
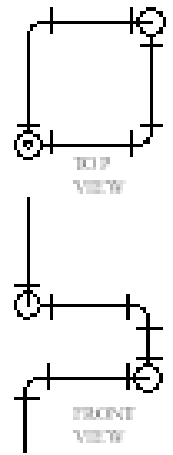

Fig. B (Q. no. 2c)



ORTHOGRAPHIC PROJECTION

Fig.(C);Q. 3(c),5(b) & 6(c)